

1 Schedule drawing

1.1 Schedule drawing WOLFF 700 B

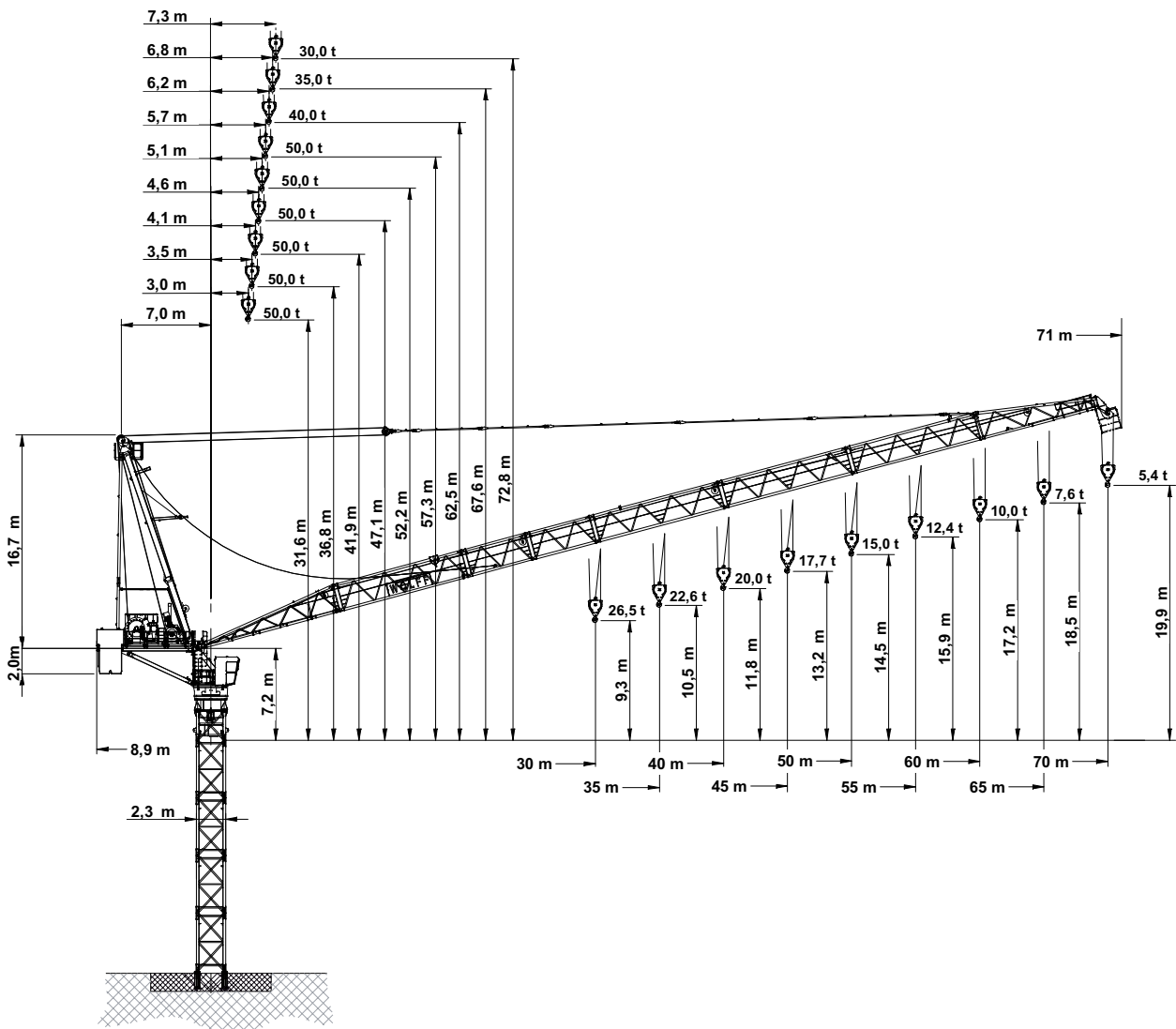

Item	Data
Crane type	BGL GROUP C.0.11.710
Design	Overhead travelling crane with top slewing luffing jib, with climbing feature
Type of setup	Stationary or travelling
Basis of calculation	EN
Payload torque	max. 8000 kN/m
Hoist winch	Hw 40132FU

2 Load carrying capacities

2.1 Table of load carrying capacity WOLFF 700B (single reeving)

 20 t		Operating radius (m)												LCC
			20	25	30	35	40	45	50	55	60	65	70	
JL (m)	70	7.3 – 28.0	20.0	20.0	18.4	15.1	12.7	10.8	9.3	8.1	7.0	6.2	5.4	[1]
	65	6.8 – 31.5	20.0	20.0	20.0	17.6	14.9	12.8	11.1	9.7	8.6	7.6		
	60	6.2 – 34.0	20.0	20.0	20.0	19.3	16.5	14.4	12.6	11.2	10.0			
	55	5.7 – 35.5	20.0	20.0	20.0	20.0	17.6	15.5	13.8	12.4				
	50	5.1 – 37.5	20.0	20.0	20.0	20.0	18.8	16.7	15.0					
	45	4.6 – 39.5	20.0	20.0	20.0	20.0	19.8	17.7						
	40	4.1 – 40.0	20.0	20.0	20.0	20.0	20.0							
	35	3.5 – 35.0	20.0	20.0	20.0	20.0								
	30	3.0 – 30.0	20.0	20.0	20.0									
JL			Jib length											
LCC			Load carrying capacity											

2.2 Table of load carrying capacities (kg) in meter intervals, WOLFF 700B (single reeving)

Operating radius (m)	Jib length [m]								
	30	35	40	45	50	55	60	65	70
10	20000	20000	20000	20000	20000	20000	20000	20000	20000
11	20000	20000	20000	20000	20000	20000	20000	20000	20000
12	20000	20000	20000	20000	20000	20000	20000	20000	20000
13	20000	20000	20000	20000	20000	20000	20000	20000	20000
14	20000	20000	20000	20000	20000	20000	20000	20000	20000
15	20000	20000	20000	20000	20000	20000	20000	20000	20000
16	20000	20000	20000	20000	20000	20000	20000	20000	20000
17	20000	20000	20000	20000	20000	20000	20000	20000	20000
18	20000	20000	20000	20000	20000	20000	20000	20000	20000
19	20000	20000	20000	20000	20000	20000	20000	20000	20000
20	20000	20000	20000	20000	20000	20000	20000	20000	20000
21	20000	20000	20000	20000	20000	20000	20000	20000	20000
22	20000	20000	20000	20000	20000	20000	20000	20000	20000
23	20000	20000	20000	20000	20000	20000	20000	20000	20000
24	20000	20000	20000	20000	20000	20000	20000	20000	20000
25	20000	20000	20000	20000	20000	20000	20000	20000	20000
26	20000	20000	20000	20000	20000	20000	20000	20000	20000
27	20000	20000	20000	20000	20000	20000	20000	20000	20000
28	20000	20000	20000	20000	20000	20000	20000	20000	20000
29	20000	20000	20000	20000	20000	20000	20000	20000	19160
30	20000	20000	20000	20000	20000	20000	20000	20000	18380
31		20000	20000	20000	20000	20000	20000	20000	17650
32		20000	20000	20000	20000	20000	20000	19620	16960
33		20000	20000	20000	20000	20000	20000	18910	16310
34		20000	20000	20000	20000	20000	20000	18230	15710
35		20000	20000	20000	20000	20000	19340	17590	15130
36			20000	20000	20000	19700	18720	16990	14590
37			20000	20000	20000	19130	18130	16420	14080
38			20000	20000	19740	18590	17570	15880	13600
39			20000	20000	19230	18080	17040	15370	13140
40			20000	19760	18750	17590	16540	14890	12700
41				19310	18290	17120	16060	14430	12280
42				18880	17860	16680	15600	13990	11890
43				18470	17440	16260	15170	13570	11510
44				18080	17050	15860	14760	13160	11150
45				17700	16670	15470	14360	12780	10810
46					16300	15110	13980	12420	10480
47					15960	14760	13620	12070	10160
48					15630	14420	13270	11730	9860
49					15310	14090	12940	11410	9570
50					15000	13780	12620	11100	9290
51						13490	12310	10800	9030
52						13200	12010	10510	8770
53						12920	11730	10240	8520
54						12660	11450	9980	8280
55						12400	11190	9720	8050
56							10930	9470	7830
57							10690	9240	7620
58							10450	9010	7410
59							10220	8790	7210
60							10000	8570	7020
61								8360	6840
62								8160	6660
63								7970	6480
64								7780	6310
65								7600	6150
66									5990
67									5840
68									5690
69									5540
70									5400

2.3 Table of load carrying capacity WOLFF 700B (double reeving)

		Operating radius [m]	max. LCC	20	25	30	35	40	45	50	55	60	65	70	
JL [m]	70	7.3 – 19.0	30.0 t	28.3	21.6	17.2	14.0	11.6	9.8	8.3	7.1	6.1	5.2	4.5	LCC [t]
	65	6.8 – 18.5	35.0 t 40.0 t	32.0	24.7	19.8	16.4	13.7	11.7	10.1	8.8	7.6	6.7		
	60	6.2 – 17.5		34.6	26.9	21.8	18.2	15.5	13.3	11.6	10.3	9.1			
	55	5.7 – 18.0		35.8	28.1	23.1	19.4	16.7	14.6	12.9	11.5				
	50	5.1 – 18.5		36.9	29.3	24.2	20.6	17.9	15.8	14.1					
	45	4.6 – 19.0		38.0	30.4	25.3	21.6	18.9	16.8						
	40	4.1 – 19.5		39.0	31.3	26.1	22.5	19.7							
	35	3.5 – 20.0		40.0	31.9	26.5	22.6								
30	3.0 – 20.0	40.0		31.9	26.5										
JL	Jib length														
LCC	Load carrying capacity														

2.4 Table of load carrying capacities (kg) in meter intervals, WOLFF 700B (double reeving)

Operating radius (m)	Jib length [m]								
	30	35	40	45	50	55	60	65	70
10	40000	40000	40000	40000	40000	40000	40000	35000	30000
11	40000	40000	40000	40000	40000	40000	40000	35000	30000
12	40000	40000	40000	40000	40000	40000	40000	35000	30000
13	40000	40000	40000	40000	40000	40000	40000	35000	30000
14	40000	40000	40000	40000	40000	40000	40000	35000	30000
15	40000	40000	40000	40000	40000	40000	40000	35000	30000
16	40000	40000	40000	40000	40000	40000	40000	35000	30000
17	40000	40000	40000	40000	40000	40000	40000	35000	30000
18	40000	40000	40000	40000	40000	40000	38790	35000	30000
19	40000	40000	40000	40000	38920	37770	36560	33960	30000
20	40000	40000	39010	37990	36920	35760	34550	32030	28250
21	38070	38070	37170	36180	35110	33950	32730	30290	26670
22	36320	36310	35500	34520	33460	32300	31080	28710	25230
23	34720	34700	33970	33020	31960	30790	29570	27260	23910
24	33250	33230	32570	31630	30580	29410	28190	25930	22710
25	31900	31880	31290	30360	29310	28140	26910	24710	21600
26	30650	30630	30100	29190	28140	26960	25740	23590	20580
27	29500	29470	29000	28100	27060	25880	24650	22550	19630
28	28430	28400	27980	27090	26050	24870	23640	21580	18750
29	27430	27400	27020	26150	25110	23930	22700	20680	17930
30	26500	26470	26140	25280	24240	23050	21820	19840	17170
31		25590	25310	24460	23420	22230	21000	19050	16450
32		24780	24530	23690	22660	21470	20230	18310	15780
33		24010	23800	22970	21940	20740	19510	17620	15150
34		23280	23110	22290	21260	20060	18830	16970	14560
35		22600	22460	21640	20620	19420	18190	16350	14000
36			21850	21040	20020	18820	17580	15770	13470
37			21270	20470	19440	18250	17010	15220	12970
38			20720	19920	18900	17700	16470	14700	12500
39			20200	19410	18390	17190	15950	14210	12050
40			19700	18920	17900	16700	15460	13740	11630
41				18450	17440	16230	15000	13290	11220
42				18010	17000	15790	14550	12870	10830
43				17590	16580	15370	14130	12460	10470
44				17190	16170	14970	13730	12070	10110
45				16800	15790	14580	13340	11700	9780
46					15420	14210	12970	11350	9460
47					15070	13860	12620	11010	9150
48					14730	13520	12280	10690	8850
49					14410	13200	11960	10380	8570
50					14100	12890	11640	10080	8300
51						12590	11350	9790	8040
52						12300	11060	9510	7790
53						12020	10780	9250	7550
54						11760	10510	8990	7310
55						11500	10260	8750	7090
56							10010	8510	6880
57							9770	8280	6670
58							9540	8060	6470
59							9320	7840	6270
60							9100	7640	6080
61								7440	5900
62								7240	5730
63								7060	5560
64								6880	5390
65								6700	5230
66									5080
67									4930
68									4780
69									4640
70									4500



2.5 Load carrying capacity table WOLFF 700B (triple reeving)

 50 t		Operating radius (m)												LCC	
			20	25	30	35	40	45	50	55	60	65	70		
JL (m)	55	5.7 – 14.2	34.6	27.0	22.0	18.4	15.7	13.6	11.9	10.5					LCC [t]
	50	5.1 – 14.5	35.7	28.2	23.2	19.6	16.9	14.8	13.1						
	45	4.6 – 14.8	36.8	29.2	24.2	20.6	17.9	15.8							
	40	4.1 – 15.2	37.9	30.2	25.1	21.4	18.7								
	35	3.5 – 15.6	38.7	30.7	25.4	21.6									
30	3.0 – 15.6	38.8	30.8	25.5											
JL		Jib length													
LCC		Load carrying capacity													

2.6 Table of load carrying capacities (kg) in meter intervals, WOLFF 700B (triple reeving)

Operating radius (m)	Jib length [m]								
	30	35	40	45	50	55	60	65	70
10	50000	50000	50000	50000	50000	50000	-	-	-
11	50000	50000	50000	50000	50000	50000	-	-	-
12	50000	50000	50000	50000	50000	50000	-	-	-
13	50000	50000	50000	50000	50000	50000	-	-	-
14	50000	50000	50000	50000	50000	50000	-	-	-
15	50000	50000	50000	49320	48270	47160	-	-	-
16	48720	48720	47480	46180	45130	44010	-	-	-
17	45800	45780	44650	43410	42360	41230	-	-	-
18	43190	43170	42150	40940	39890	38760	-	-	-
19	40870	40830	39900	38740	37690	36550	-	-	-
20	38770	38730	37880	36750	35710	34560	-	-	-
21	36880	36820	36060	34950	33910	32760	-	-	-
22	35150	35090	34400	33320	32280	31120	-	-	-
23	33580	33520	32880	31830	30790	29630	-	-	-
24	32140	32070	31490	30470	29430	28260	-	-	-
25	30810	30730	30210	29210	28170	27000	-	-	-
26	29580	29510	29030	28050	27010	25830	-	-	-
27	28450	28370	27940	26970	25940	24760	-	-	-
28	27400	27310	26920	25980	24940	23760	-	-	-
29	26420	26320	25980	25050	24010	22830	-	-	-
30	25500	25410	25090	24180	23150	21960	-	-	-
31		24550	24270	23370	22340	21140	-	-	-
32		23740	23500	22610	21580	20380	-	-	-
33		22980	22770	21890	20860	19670	-	-	-
34		22270	22090	21220	20190	18990	-	-	-
35		21600	21440	20590	19560	18360	-	-	-
36			20830	19990	18960	17760	-	-	-
37			20260	19420	18400	17190	-	-	-
38			19710	18890	17860	16650	-	-	-
39			19190	18380	17350	16140	-	-	-
40			18700	17900	16870	15660	-	-	-
41				17440	16410	15190	-	-	-
42				17000	15970	14760	-	-	-
43				16580	15550	14340	-	-	-
44				16180	15160	13940	-	-	-
45				15800	14770	13560	-	-	-
46					14410	13190	-	-	-
47					14060	12840	-	-	-
48					13730	12500	-	-	-
49					13410	12180	-	-	-
50					13100	11870	-	-	-
51						11580	-	-	-
52						11290	-	-	-
53						11020	-	-	-
54						10750	-	-	-
55						10500	-	-	-
56							-	-	-
57							-	-	-
58							-	-	-
59							-	-	-
60							-	-	-
61							-	-	-
62							-	-	-
63							-	-	-
64							-	-	-
65							-	-	-
66							-	-	-
67							-	-	-
68							-	-	-
69							-	-	-
70							-	-	-

3 Tower combinations

	<p>⚠ DANGER</p> <p>Usage of incorrect tower combinations. The slewing tower crane may overturn.</p> <ol style="list-style-type: none">1) Use the specified tower combinations.2) If you need another tower combination that is not specified here, please contact WOLFFKRAN to get an approved alternative setup in writing.
	<p>NOTICE</p> <p>All tower combinations apply to free standing slewing tower cranes without climbing gear.</p>
	<p>NOTICE</p> <p>For tower combination with tower element TV 25 and UV 25 please contact WOLFFKRAN.</p>

3.1 Tower combinations on foundation anchor (HT23 - connection)

Jib length	30 m – 35 m			
Item				
1	4.5 m	HT 23		
2	9.0 m	HT 23		
3	13.5 m	HT 23		
4	18.0 m	HT 23		
5	22.5 m	HT 23		
6	27.0 m	HT 23		
7	31.5 m	HT 23		
8	36.0 m	HT 23		
9	40.5 m	HT 23		
10	45.0 m	HT 23		
11	49.5 m	HT 23		
Foundation		FUA G 160		
Tower height [m]		49.5		

WOLFFKRAN

Jib length	30 m – 35 m			
Item				
1	4.5 m	HT 23		
2	9.0 m	HT 23		
3	13.5 m	HT 23		
4	18.0 m	HT 23		
5	22.5 m	HT 23		
6	27.0 m	HT 23		
7	31.5 m	HT 23		
8	36.0 m	HT 23		
9	40.5 m	HT 23		
10	45.0 m	HT 23		
11	56.3 m	BT 23		
Foundation		FUA G 210		
Tower height [m]		56.3		

WOLFFKRAN

Jib length	30 m – 35 m			
Item				
1	4.5 m	HT 23		
2	9.0 m	HT 23		
3	13.5 m	HT 23		
4	18.0 m	HT 23		
5	22.5 m	HT 23		
6	27.0 m	HT 23		
7	31.5 m	HT 23		
8	36.0 m	HT 23		
9	37.2 m	VR 23/25-29		
10	41.7 m	UV 29		
11	46.2 m	UV 29		
12	50.7 m	UV 29		
13	55.2 m	UV 29		
14	65.2 m	BT 29		
Foundation		FUA BT 29		
Tower height [m]		65.2		

WOLFFKRAN

Jib length	40 m – 70 m				
Item					
1	4.5 m	HT 23			
2	9.0 m	HT 23			
3	13.5 m	HT 23			
4	18.0 m	HT 23			
5	22.5 m	HT 23			
6	27.0 m	HT 23			
7	31.5 m	HT 23			
8	36.0 m	HT 23			
9	40.5 m	HT 23			
10	45.0 m	HT 23			
Foundation		FUA G 160			
Tower height [m]		45.0			

WOLFFKRAN

Jib length	40 m – 70 m			
Item				
1	4.5 m	HT 23		
2	9.0 m	HT 23		
3	13.5 m	HT 23		
4	18.0 m	HT 23		
5	22.5 m	HT 23		
6	27.0 m	HT 23		
7	31.5 m	HT 23		
8	36.0 m	HT 23		
9	40.5 m	HT 23		
10	51.8 m	BT 23		
Foundation		FUA G 210		
Tower height [m]		51.8		

WOLFFKRAN

Jib length	40 m – 70 m			
Item				
1	4.5 m	HT 23		
2	9.0 m	HT 23		
3	13.5 m	HT 23		
4	18.0 m	HT 23		
5	22.5 m	HT 23		
6	27.0 m	HT 23		
7	31.5 m	HT 23		
8	36.0 m	HT 23		
9	37.2 m	VR 23/25-29		
10	41.7 m	UV 29		
11	46.2 m	UV 29		
12	50.7 m	UV 29		
13	60.7 m	BT 29		
Foundation		FUA BT 29		
Tower height [m]		60.7		

3.2 Tower combinations on cross frame (HT23 - connection)

Jib length	30 m – 35 m			
Item				
1	4.5 m	HT 23	HT 23	
2	9.0 m	HT 23	HT 23	
3	13.5 m	HT 23	HT 23	
4	18.0 m	HT 23	HT 23	
5	22.5 m	HT 23	HT 23	
6	27.0 m	HT 23	HT 23	
7	31.5 m	HT 23	HT 23	
8	36.0 m	HT 23	HT 23	
9	40.5 m	HT 23	HT 23	
10	45.0 m	HT 23	HT 23	
11	49.5 m	HT 23	HT 23	
Substructure		KR 12-60 KR 12-60/80	KR 16-80 KR 16-80/100	
[m x m]		6.0 x 6.0 8.0 x 8.0	8.0 x 8.0 10.0 x 10.0	
Substructure height [m]		1.4	1.8	
Tower height [m]		50.9	51.3	

WOLFFKRAN

Jib length	30 m – 35 m				
Item					
1	4.5 m	HT 23			
2	9.0 m	HT 23			
3	13.5 m	HT 23			
4	18.0 m	HT 23			
5	22.5 m	HT 23			
6	27.0 m	HT 23			
7	31.5 m	HT 23			
8	36.0 m	HT 23			
9	37.2 m	VR 23/25-29			
10	41.7 m	UV 29			
11	46.2 m	UV 29			
12	50.7 m	UV 29			
13	55.2 m	UV 29			
14	65.2 m	BT 29			
Substructure		KR 16-80 KR 16-80/100			
[m x m]		8.0 x 8.0 10.0 x 10.0			
Substructure height [m]		1.8			
Tower height [m]		67.0			

WOLFFKRAN

Jib length	40 m – 50 m			
Item				
1	4.5 m	HT 23	HT 23	
2	9.0 m	HT 23	HT 23	
3	13.5 m	HT 23	HT 23	
4	18.0 m	HT 23	HT 23	
5	22.5 m	HT 23	HT 23	
6	27.0 m	HT 23	HT 23	
7	31.5 m	HT 23	HT 23	
8	36.0 m	HT 23	HT 23	
9	40.5 m	HT 23	HT 23	
10	45.0 m	HT 23	HT 23	
Substructure		KR 12-60 KR 12-60/80	KR 16-80 KR 16-80/100	
[m x m]		6.0 x 6.0 8.0 x 8.0	8.0 x 8.0 10.0 x 10.0	
Substructure height [m]		1.4	1.8	
Tower height [m]		46.4	46.8	

Jib length	40 m – 50 m				
Item					
1	4.5 m	HT 23			
2	9.0 m	HT 23			
3	13.5 m	HT 23			
4	18.0 m	HT 23			
5	22.5 m	HT 23			
6	27.0 m	HT 23			
7	31.5 m	HT 23			
8	36.0 m	HT 23			
9	37.2 m	VR 23/25-29			
10	41.7 m	UV 29			
11	46.2 m	UV 29			
12	50.7 m	UV 29			
13	55.2 m	UV 29			
14	65.2 m	BT 29			
Substructure		KR 16-80 KR 16-80/100			
[m x m]		8.0 x 8.0 10.0 x 10.0			
Substructure height [m]		1.8			
Tower height [m]		67.0			

WOLFFKRAN

Jib length	55 m – 60 m			
Item				
1	4.5 m	HT 23	HT 23	
2	9.0 m	HT 23	HT 23	
3	13.5 m	HT 23	HT 23	
4	18.0 m	HT 23	HT 23	
5	22.5 m	HT 23	HT 23	
6	27.0 m	HT 23	HT 23	
7	31.5 m	HT 23	HT 23	
8	36.0 m	HT 23	HT 23	
9	40.5 m	HT 23	HT 23	
10	45.0 m	HT 23	HT 23	
Substructure		KR 12-60 KR 12-60/80	KR 16-80 KR 16-80/100	
[m x m]		6.0 x 6.0 8.0 x 8.0	8.0 x 8.0 10.0 x 10.0	
Substructure height [m]		1.4	1.8	
Tower height [m]		46.4	46.8	

WOLFFKRAN

Jib length	55 m – 60 m				
Item					
1	4.5 m	HT 23			
2	9.0 m	HT 23			
3	13.5 m	HT 23			
4	18.0 m	HT 23			
5	22.5 m	HT 23			
6	27.0 m	HT 23			
7	31.5 m	HT 23			
8	36.0 m	HT 23			
9	37.2 m	VR 23/25-29			
10	41.7 m	UV 29			
11	46.2 m	UV 29			
12	50.7 m	UV 29			
13	60.7 m	BT 29			
Substructure		KR 16-80 KR 16-80/100			
[m x m]		8.0 x 8.0 10.0 x 10.0			
Substructure height [m]		1.8			
Tower height [m]		62.5			

WOLFFKRAN

Jib length	65 m			
Item				
1	4.5 m	HT 23	HT 23	
2	9.0 m	HT 23	HT 23	
3	13.5 m	HT 23	HT 23	
4	18.0 m	HT 23	HT 23	
5	22.5 m	HT 23	HT 23	
6	27.0 m	HT 23	HT 23	
7	31.5 m	HT 23	HT 23	
8	36.0 m	HT 23	HT 23	
9	40.5 m	HT 23	HT 23	
10	45.0 m	HT 23	HT 23	
Substructure		KR 12-60 KR 12-60/80	KR 16-80 KR 16-80/100	
[m x m]		6.0 x 6.0 8.0 x 8.0	8.0 x 8.0 10.0 x 10.0	
Substructure height [m]		1.4	1.8	
Tower height [m]		46.4	46.8	

WOLFFKRAN

Jib length	65 m				
Item					
1	4.5 m	HT 23			
2	9.0 m	HT 23			
3	13.5 m	HT 23			
4	18.0 m	HT 23			
5	22.5 m	HT 23			
6	27.0 m	HT 23			
7	31.5 m	HT 23			
8	36.0 m	HT 23			
9	37.2 m	VR 23/25-29			
10	41.7 m	UV 29			
11	46.2 m	UV 29			
12	56.2 m	BT 29			
Substructure		KR 16-80 KR 16-80/100			
[m x m]		8.0 x 8.0 10.0 x 10.0			
Substructure height [m]		1.8			
Tower height [m]		58.0			

WOLFFKRAN

Jib length	70 m			
Item				
1	4.5 m	HT 23	HT 23	
2	9.0 m	HT 23	HT 23	
3	13.5 m	HT 23	HT 23	
4	18.0 m	HT 23	HT 23	
5	22.5 m	HT 23	HT 23	
6	27.0 m	HT 23	HT 23	
7	31.5 m	HT 23	HT 23	
8	36.0 m	HT 23	HT 23	
9	40.5 m	HT 23	HT 23	
10	45.0 m		HT 23	
Substructure		KR 12-60 KR 12-60/80	KR 16-80 KR 16-80/100	
[m x m]		6.0 x 6.0 8.0 x 8.0	8.0 x 8.0 10.0 x 10.0	
Substructure height [m]		1.4	1.8	
Tower height [m]		41.9	46.8	

WOLFFKRAN

Jib length	70 m				
Item					
1	4.5 m	HT 23			
2	9.0 m	HT 23			
3	13.5 m	HT 23			
4	18.0 m	HT 23			
5	22.5 m	HT 23			
6	27.0 m	HT 23			
7	31.5 m	HT 23			
8	36.0 m	HT 23			
9	37.2 m	VR 23/25-29			
10	41.7 m	UV 29			
11	46.2 m	UV 29			
12	56.2 m	BT 29			
Substructure		KR 16-80 KR 16-80/100			
[m x m]		8.0 x 8.0 10.0 x 10.0			
Substructure height [m]		1.8			
Tower height [m]		58.0			

3.3 Tower combinations on mobile cross frame (HT 23 connection)

Jib length	30 m – 35 m			
Item				
1	4.5 m	HT 23	HT 23	
2	9.0 m	HT 23	HT 23	
3	13.5 m	HT 23	HT 23	
4	18.0 m	HT 23	HT 23	
5	22.5 m	HT 23	HT 23	
6	27.0 m	HT 23	HT 23	
7	31.5 m	HT 23	HT 23	
8	36.0 m	HT 23	HT 23	
Substructure		KRF6 12-60/80	KRF 16-80/100	
[m x m]		8.0 x 8.0	10.0 x 10.0	
Substructure height [m]		2.9	3.3	
Tower height [m]		38.9	39.3	

WOLFFKRAN

Jib length	30 m – 35 m				
Item					
1	4.5 m	HT 23			
2	9.0 m	HT 23			
3	13.5 m	HT 23			
4	18.0 m	HT 23			
5	22.5 m	HT 23			
6	27.0 m	HT 23			
7	31.5 m	HT 23			
8	32.7 m	VR 23/25-29			
9	37.2 m	UV 29			
10	41.7 m	UV 29			
11	46.2 m	UV 29			
12	56.2 m	BT 29			
Substructure	KRF 16-80/100				
[m x m]	10.0 x 10.0				
Substructure height [m]	3.3				
Tower height [m]	59.5				

WOLFFKRAN

Jib length	40 m – 50 m				
Item					
1	4.5 m	HT 23	HT 23		
2	9.0 m	HT 23	HT 23		
3	13.5 m	HT 23	HT 23		
4	18.0 m	HT 23	HT 23		
5	22.5 m	HT 23	HT 23		
6	27.0 m	HT 23	HT 23		
7	31.5 m	HT 23	HT 23		
8	36.0 m	HT 23	HT 23		
Substructure		KRF6 12-60/80	KRF 16-80/100		
[m x m]		8.0 x 8.0	10.0 x 10.0		
Substructure height [m]		2.9	3.3		
Tower height [m]		38.9	39.3		

WOLFFKRAN

Jib length	40 m – 50 m				
Item					
1	4.5 m	HT 23			
2	9.0 m	HT 23			
3	13.5 m	HT 23			
4	18.0 m	HT 23			
5	22.5 m	HT 23			
6	27.0 m	HT 23			
7	28.2 m	VR 23/25-29			
8	32.7 m	UV 29			
9	37.2 m	UV 29			
10	41.7 m	UV 29			
11	46.2 m	UV 29			
12	56.2 m	BT 29			
Substructure	KRF 16-80/100				
[m x m]	10.0 x 10.0				
Substructure height [m]	3.3				
Tower height [m]	59.5				

WOLFFKRAN

Jib length	50 m – 60 m			
Item				
1	4.5 m	HT 23	HT 23	
2	9.0 m	HT 23	HT 23	
3	13.5 m	HT 23	HT 23	
4	18.0 m	HT 23	HT 23	
5	22.5 m	HT 23	HT 23	
6	27.0 m	HT 23	HT 23	
7	31.5 m	HT 23	HT 23	
8	36.0 m	HT 23	HT 23	
Substructure		KRF6 12-60/80	KRF 16-80/100	
[m x m]		8.0 x 8.0	10.0 x 10.0	
Substructure height [m]		2.9	3.3	
Tower height [m]		38.9	39.3	

WOLFFKRAN

Jib length	55 m – 60 m			
Item				
1	4.5 m	HT 23		
2	9.0 m	HT 23		
3	13.5 m	HT 23		
4	18.0 m	HT 23		
5	22.5 m	HT 23		
6	27.0 m	HT 23		
7	28.2 m	VR 23/25-29		
8	32.7 m	UV 29		
9	37.2 m	UV 29		
10	41.7 m	UV 29		
11	51.7 m	BT 29		
Substructure		KRF 16-80/100		
[m x m]		10.0 x 10.0		
Substructure height [m]		3.3		
Tower height [m]		55.0		

WOLFFKRAN

Jib length	65 m				
Item					
1	4.5 m	HT 23	HT 23		
2	9.0 m	HT 23	HT 23		
3	13.5 m	HT 23	HT 23		
4	18.0 m	HT 23	HT 23		
5	22.5 m	HT 23	HT 23		
6	27.0 m	HT 23	HT 23		
7	31.5 m	HT 23	HT 23		
8	36.0 m	HT 23	HT 23		
Substructure		KRF6 12-60/80	KRF 16-80/100		
[m x m]		8.0 x 8.0	10.0 x 10.0		
Substructure height [m]		2.9	3.3		
Tower height [m]		38.9	39.3		

WOLFFKRAN

Jib length	65 m			
Item				
1	4.5 m	HT 23		
2	9.0 m	HT 23		
3	13.5 m	HT 23		
4	18.0 m	HT 23		
5	22.5 m	HT 23		
6	27.0 m	HT 23		
7	28.2 m	VR 23/25-29		
8	32.7 m	UV 29		
9	37.2 m	UV 29		
10	41.7 m	UV 29		
11	51.7 m	BT 29		
Substructure		KRF 16-80/100		
[m x m]		10.0 x 10.0		
Substructure height [m]		3.3		
Tower height [m]		55.0		



WOLFFKRAN



Jib length	70 m				
Item					
1	4.5 m	HT 23	HT 23		
2	9.0 m	HT 23	HT 23		
3	13.5 m	HT 23	HT 23		
4	18.0 m	HT 23	HT 23		
5	22.5 m	HT 23	HT 23		
6	27.0 m	HT 23	HT 23		
7	31.5 m	HT 23	HT 23		
8	36.0 m	HT 23	HT 23		
Substructure		KRF6 12-60/80	KRF 16-80/100		
[m x m]		8.0 x 8.0	10.0 x 10.0		
Substructure height [m]		2.9	3.3		
Tower height [m]		38.9	39.3		

WOLFFKRAN

Jib length	70 m			
Item				
1	4.5 m	HT 23		
2	9.0 m	HT 23		
3	13.5 m	HT 23		
4	18.0 m	HT 23		
5	22.5 m	HT 23		
6	27.0 m	HT 23		
7	28.2 m	VR 23/25-29		
8	32.7 m	UV 29		
9	37.2 m	UV 29		
10	41.7 m	UV 29		
11	51.7 m	BT 29		
Substructure		KRF 16-80/100		
[m x m]		10.0 x 10.0		
Substructure height [m]		3.3		
Tower height [m]		55.0		

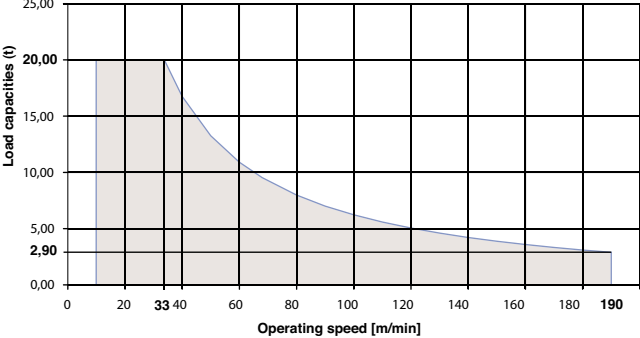
4 Operating speeds

Drive unit [type]	Operating speed Carrying load	Hook travel distance max. [m]	Power [kW]	Total connected load [kVA]
Hw40132FU	Lifting / lowering	990	132	241.0
				Total connected load at coincidence factor of 0.7
				
Max. tower height (m) (with jib length of 70 m)				905

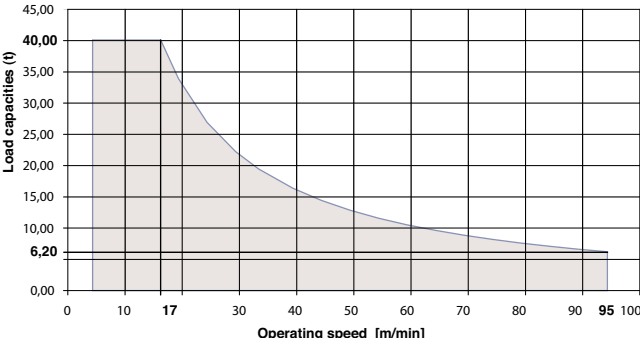
Drive unit [type]	Operating speed Carrying load	Hook travel distance max. [m]	Power [kW]	Total connected load [kVA]
Hw40132FU	Lifting / lowering	495	132	241.0
				Total connected load at coincidence factor of 0.7
				
Max. tower height (m) (with jib length of 70 m)				410



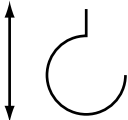
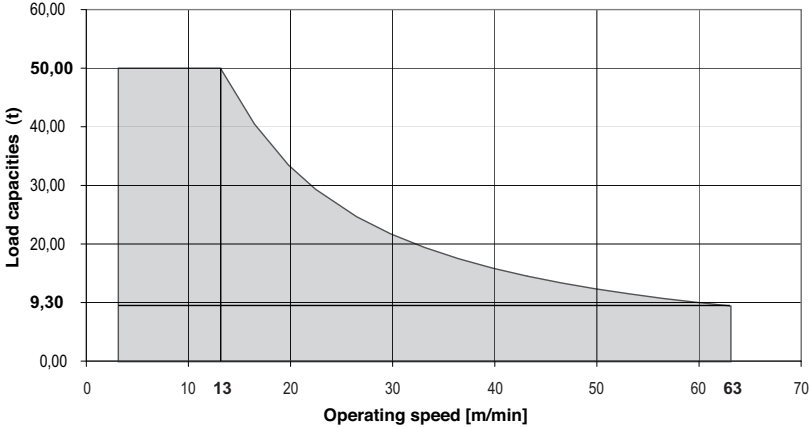

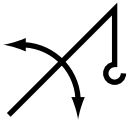
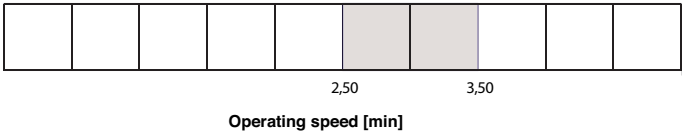

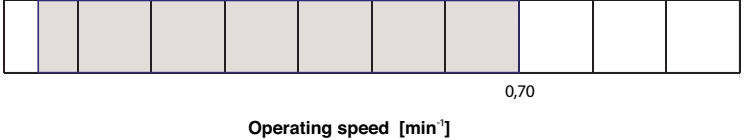



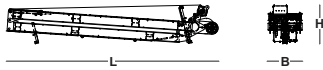



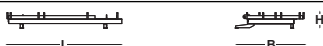

WOLFFKRAN

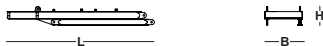

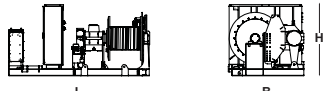
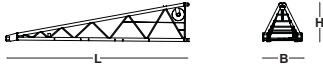

Drive unit [type]	Operating speed Carrying load	Hook travel distance max. [m]	Power [kW]	Total connected load [kVA]	
Hw40132FU	Lifting / lowering		330	132	241.0 Total connected load at coincidence factor of 0.7
					
Max. tower height (m) (with jib length of 70 m)				245	

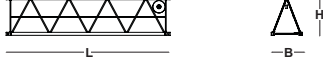
Drive unit [type]	Operating speeds	Power [kW]	Total connected load [kVA]
EW 12110FU	Jib luffing in / out	110	241.0 Total connected load at coincidence factor of 0.7
			

Drive unit [type]	Operating speeds	Power [kW]	Total connected load [kVA]
SG	Slewing	2 x 7.5	241.0 Total connected load at coincidence factor of 0.7
			

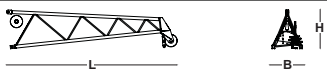
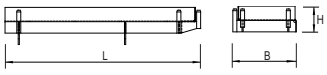
5 Package list 700 B

Quantity	Description	Package	L [m]	W [m]	H [m]	Weight [kg]	Volume [m ³]
1	Tower head section upper part including pulley block and platforms		11.95	2.50	2.57	9500	76.78
1	Tower head section brace		10.18	0.72	0.43	1600	3.15
1	Tower head section lower part		8.52	3.05	2.66	20400	69.12
	Connecting block with ladder		4.27	2.35	2.30	4500	23.08
	Slewing frame including railings and slewing gear motor (dismantled)		2.32	2.57	2.97	13300	17.71
	Tower top lower part adapter		2.32	2.80	2.52	2600	14.73
1	Driver's cab suspension		2.72	2.00	0.57	400	3.10
1	Driver's cab		1.90	1.44	2.34	750	6.40
1	Counter jib with struts and platforms		8.05	2.50	1.09	5900	21.94
1	Machine platform with derricking winch, 2. brake		1.82	2.23	2.60	4700	10.55
1	Machine platform with hoist gear, 2 brake (incl. 1000 m Ø 32 mm hoisting rope = 5 tons)		4.85	2.60	2.45	17500	30.89
1	Jib section 1		11.88	2.53	2.25	4100	67.63
1	Jib section 2		10.60	1.98	2.20	3000	46.17
1	Jib section 3		5.43	1.98	2.20	1600	23.65
1	Jib section 4		5.43	1.98	2.20	1400	23.65
1	Jib section 5		10.60	1.98	2.20	2400	46.17
2	Jib section 6		10.60	1.98	2.20	2100	46.17

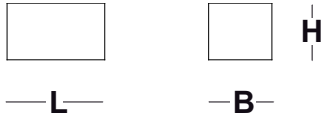
Quantity	Description	Package	L [m]	W [m]	H [m]	Weight [kg]	Volume [m³]
1	Jib section 7 (without platforms)		10.75	1.98	2.23	3500	47.47
1	Pedestals		3.1	0.5	1.5	500	2.33
	Snatch block (single reeving)		1.08	0.34	1.99	600	0.73
	Snatch block (double reeving)		1.20	0.40	1.99	1000	0.96
	Snatch block, triple reeving		1.20	0.50	1.99	1500	1.20
1	Stay rods for 70 m operating radius		10.53	0.60	0.19	2200	1.20
1	Auxiliary crane		3.37	0.40	3.43	300	4.62
	Standard railings		2.60	1.10	0.65	300	1.86
1	Box (small parts)		0.63	0.50	0.38	100	1.12

6 Assembly weights

6.1 Counterweight blocks



NOTICE

The described diagrams of the counterweights and central ballast blocks only show sketches. Have them issue the reinforcement charts by experts.

6.1.1 Counterweight block, 4.5 t

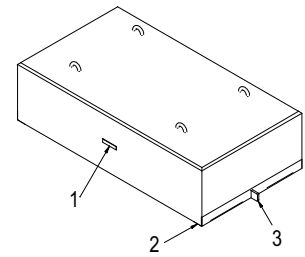
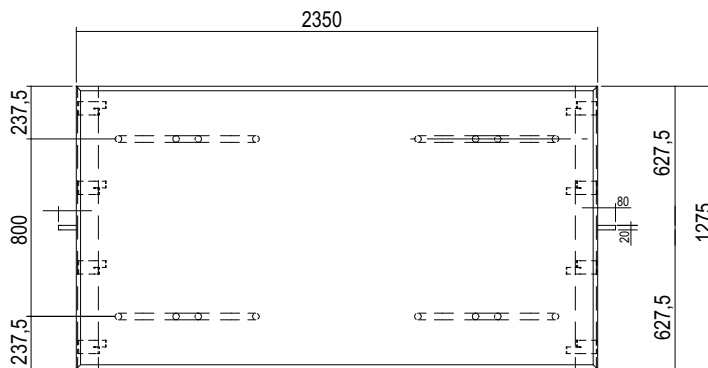
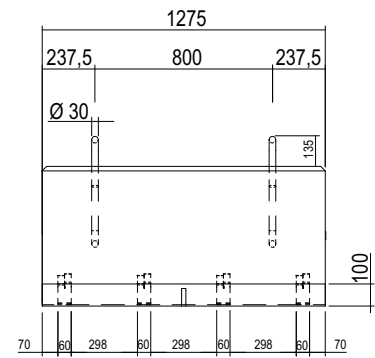
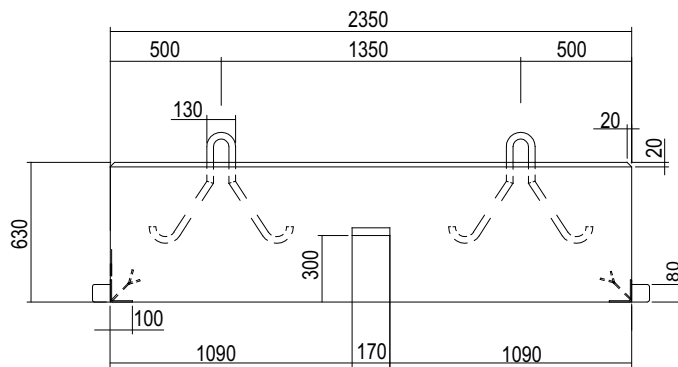

Data counterweight block 4.5 t

Item	Data
Material	Concrete, min. C 20/25
Max. permitted weight tolerance	+/- 3 %
Order number	30049318
1	Component identifier
2	Border protection
3	Adjustment

6.1.2 Counterweight block, 5.97 t

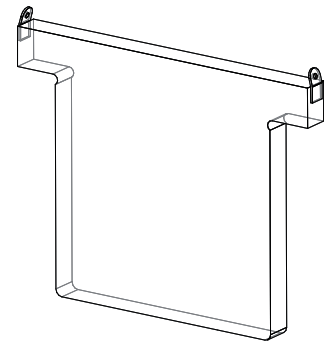
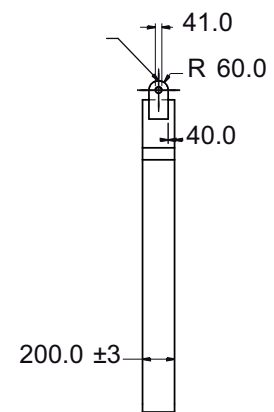
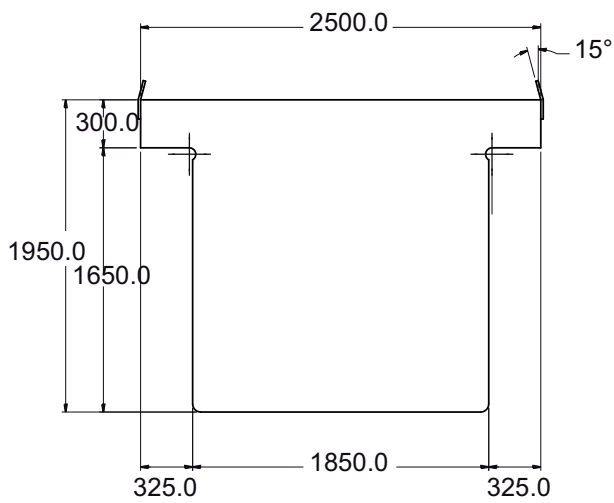

Data counterweight block 5.97 t

Item	Data
Material	Material quality S235JR, max. carbon content 0.25%
Max. permitted weight tolerance	+/- 3 %
Order number	30046411

6.1.3 Counterweight block, 8.0 t

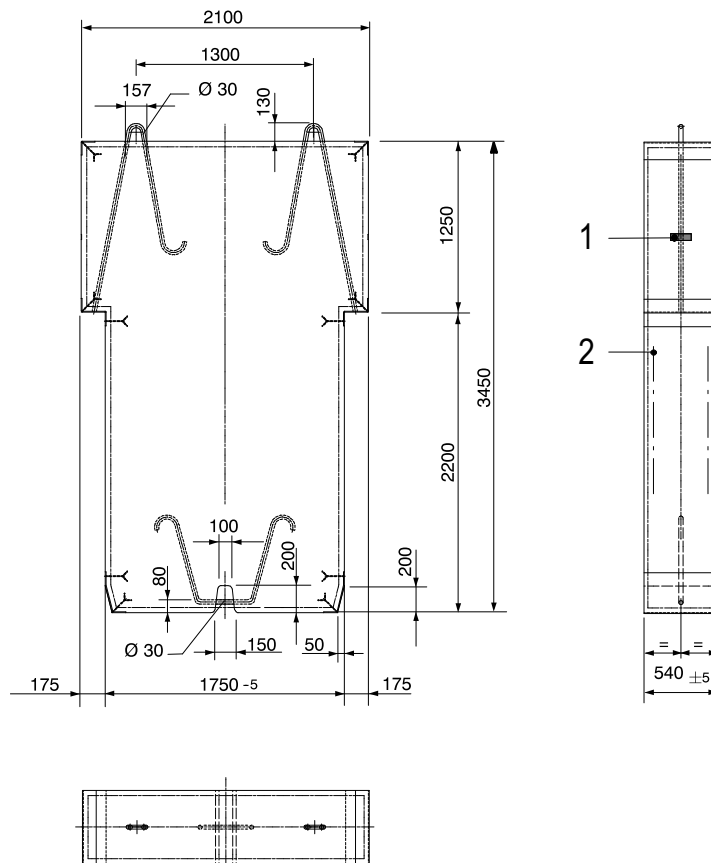

Data counterweight block 8.0 t

Item	Data
Material	Concrete, min. C 20/25
Max. permitted weight tolerance	+/- 3 %
Order number	30043944
1	Component identifier
2	Structural steel reinforcement

6.2 Total weight jib assembly

Complete jib: mechanical parts, brace plate, supports, assembly brace ropes, assembly rope guides, snatch block

Jib length [m]	Weight [kg] WOLFF 700 B
70.0	23300
65.0	21700
60.0	20800
55.0	19200
50.0	18400
45.0	16700
40.0	15600
35.0	14000
30.0	12200

6.3 Assembly weight slewing gear

Module	Crane parts	Weight [kg]	
Tower head section upper part			11015
	▪ Tower head top (including struts, pedestals and standard railing)	10520	
	▪ Pulley block	310	
	▪ Shock absorber	185	
Lower part of tower head section			20360
	▪ Lower part of tower head section	2590	
	▪ Slewing frame + KDV	13290	
	▪ Connecting block	4480	
Counterjib (including struts, pedestals and standard railing)			5900
Machine platform hoisting gear (1000 m rope = 5 to)			17500
Machine platform derricking winch			4700

6.4 Assembly weight cross frame

Module	crane part	Weight [kg]	
Cross frame KR 12 - 60 (without accessories)			14271
(6 m x 6 m)	▪ 4 x AZ 140 E 10	788	
	▪ 4 x AZ 156 M	844	
	▪ 4 x AZ 120 E 15.5	728	
	▪ 4 x AZ 140 M	788	
	▪ 4 x AZ 140 E 17	875	
	▪ 4 x AZ 160 HT 23	668	
Cross frame KR 12 – 60/80 (without accessories)			17732
(8 m x 8 m)	▪ 4 bolted spigots AZ 140 E 10	788	
	▪ 4 bolted spigots AZ 156 M	844	
	▪ 4 bolted spigots AZ 120 E15.5	728	
	▪ 4 bolted spigots AZ 140 M	788	
	▪ 4 bolted spigots AZ 140 E17	875	
	▪ 4 bolted spigots AZ 160 HT23	668	
Cross frame KR 16 - 80 (without accessories)			21450
(8 m x 8 m)	▪ 4 bolted spigots AZ 140 E KR 16 - 80	620	
	▪ 4 bolted spigots AZ 156 M KR 16-80	680	
	▪ 4 bolted spigots AZ 156S M KR 16-80	675	
Cross frame KR 16 – 80/100 (without accessories)			25400
(10 m x 10 m)	▪ 4 bolted spigots AZ 140 E KR 16 - 80	620	
	▪ 4 bolted spigots AZ 156 M KR 16-80	680	
	▪ 4 bolted spigots AZ 156S M KR 16-80	675	

6.5 Hook height above ground required for mobile cranes

For information about the height of the WOLFF slewing tower crane, refer to Tower combinations [8].

NOTICE! During assembly, allowances must be made for level differences (mobile crane to base of the slewing tower crane).

Hook height above ground required for mobile cranes (X) = height of the WOLFF slewing tower crane (A) + clearance of 29 (B).

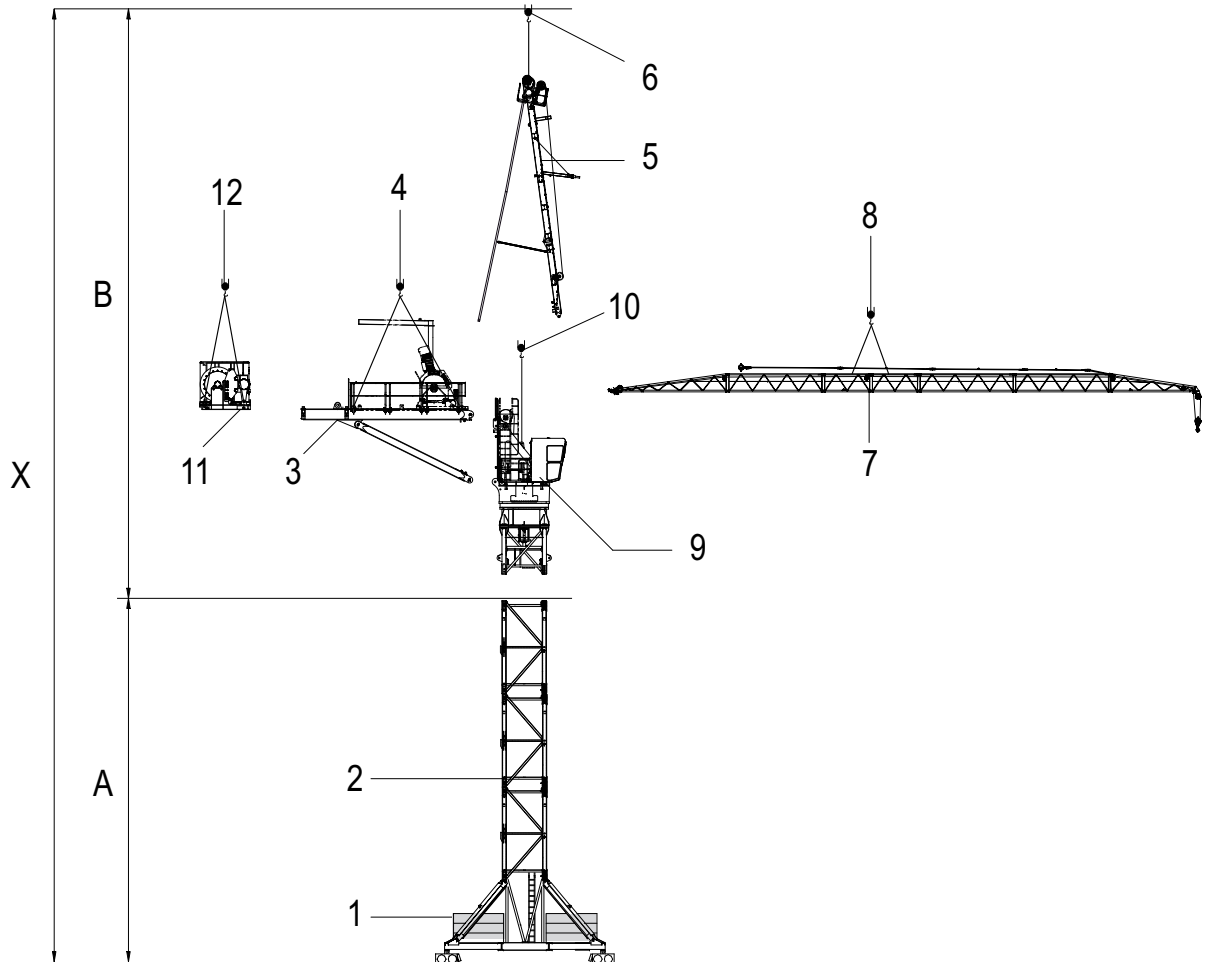

Exemplary illustration

[A]	Height of the WOLFF slewing tower crane	[B]	Clearance 29 m
[X]	Hook height above ground required for the mobile crane		
1	Substructure	7	Jib
2	Tower element	8	Four-point lifting tackle (4 m with shackle)
3	Counterjib with luffing gear platform	9	Tower head section lower part
4	Four-point lifting tackle (3 m with shackle)	10	Two-point lifting tackle (4 m with shackle)
5	Upper tower head section	11	Hoisting winch platform, complete
6	Two-point lifting tackle (3 m with shackle)	12	Four-point lifting tackle (2 m with shackle)

(see also):

- Tower combinations [8]

7 Assembly diagrams

7.1 Jib attachment diagram

	NOTICE
	For jib assembly, use a Four-point lifting tackle (4 m with shackle).

Length of jib elements

Item	Length [m]
Jib element 1	11.60
Jib element 2, 5, 6	10.35
Jib element 3, 4	5.18
Jib element 7	9.97

7.1.1 Jib attachment diagram 70 m to 60 m

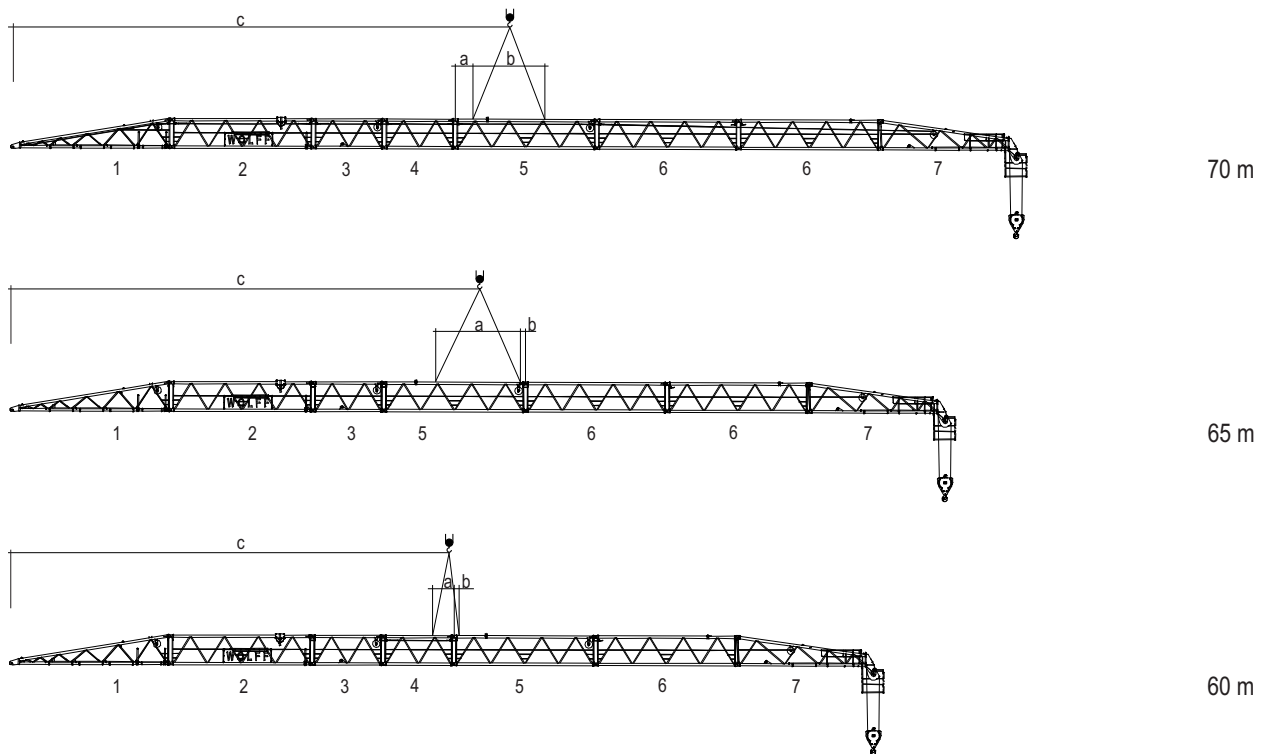

Data	Jib length (m)		
	70	65	60
a [m]	1.35	6.14	1.50
b [m]	5.17	0.38	0.20
c [m]	36.20	34.00	31.70
Weight (kg)	23300	21700	20800

7.1.2 Jib attachment diagram 55 m to 45 m

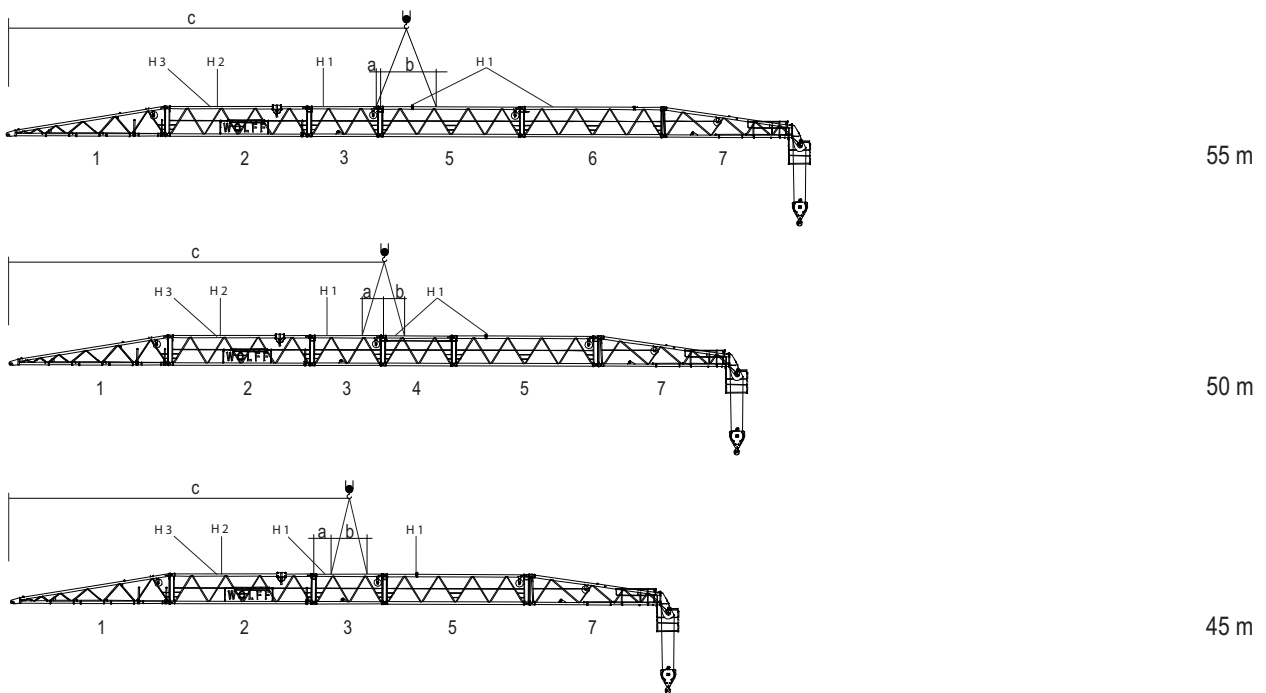

Data	Jib length (m)		
	55	50	45
a [m]	0.20	1.50	1.30
b [m]	3.87	1.50	2.57
c [m]	29.00	27.10	24.50
Weight (kg)	19200	18400	16700

7.1.3 Jib attachment diagram 40 m to 30 m

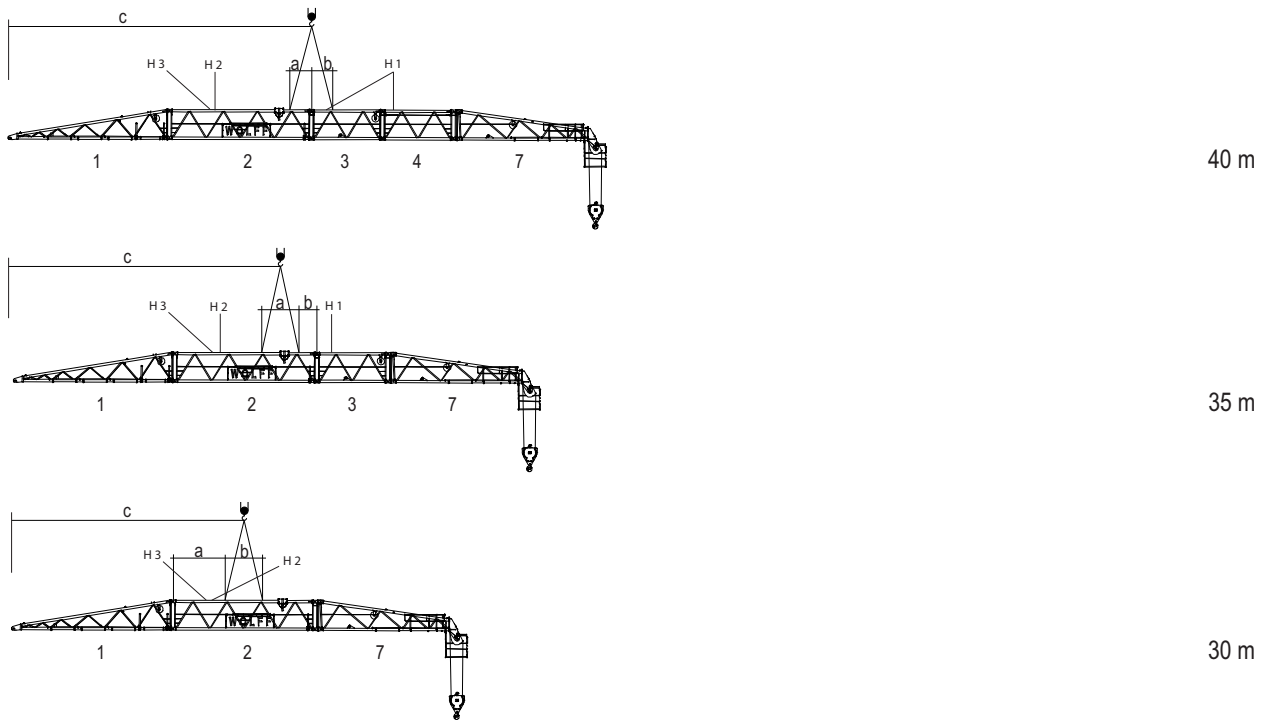

Data	Jib length (m)		
	40	35	30
a [m]	1.55	2.68	3.83
b [m]	1.50	1.35	2.69
c [m]	21.90	19.30	16.80
Weight (kg)	15600	14000	12200

7.2 Jib brace diagram

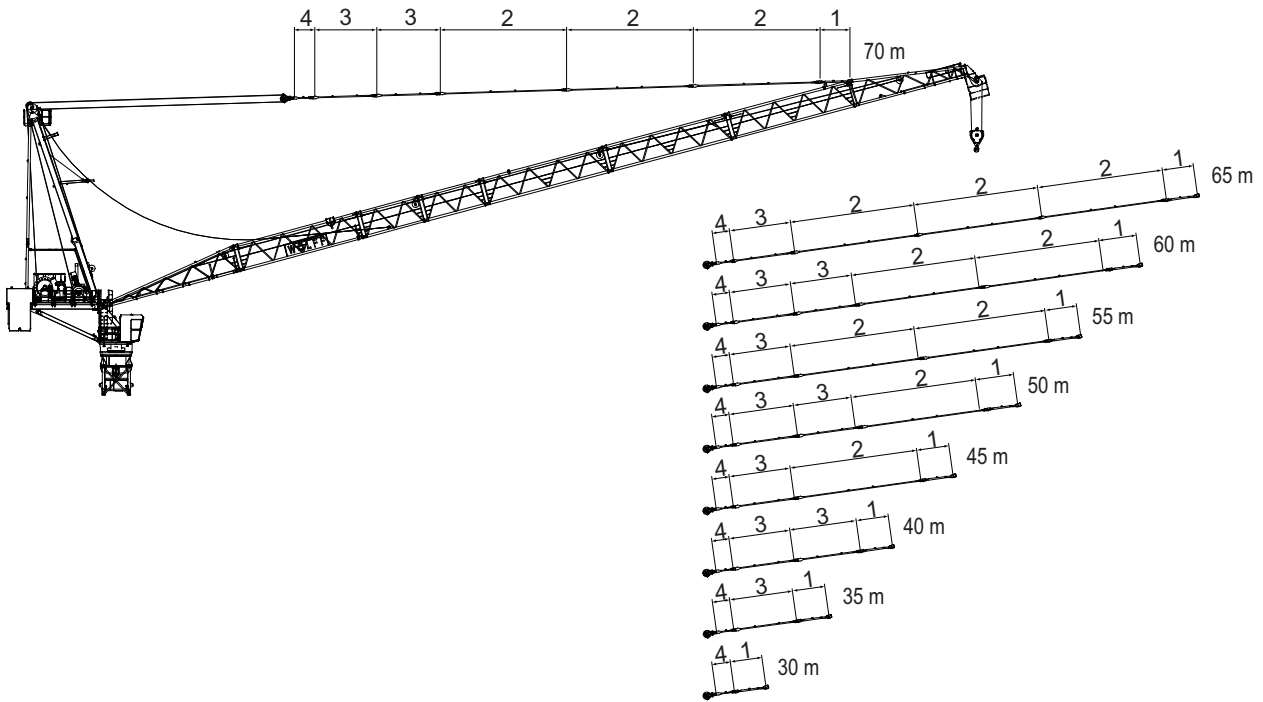

Brace table

Jib length	Lengths [m]									Total weight [t]
	Pulley block	Brace no. 4	Brace no. 3	Brace no. 3	Brace no. 2	Brace no. 2	Brace no. 2	Brace no. 1	Total length	
Jib – 70 m	0.75	1.60	5.15	5.15	10.30	10.30	10.30	2.48	46.03	2.2
Jib – 65 m	0.75	1.60	5.15		10.30	10.30	10.30	2.48	40.88	1.9
Jib – 60 m	0.75	1.60	5.15	5.15		10.30	10.30	2.48	35.73	1.7
Jib – 55 m	0.75	1.60	5.15			10.30	10.30	2.48	30.58	1.5
Jib – 50 m	0.75	1.60	5.15	5.15			10.30	2.48	25.43	1.3
Jib – 45 m	0.75	1.60	5.15				10.30	2.48	20.28	1.0
Jib – 40 m	0.75	1.60	5.15	5.15				2.48	15.13	0.8
Jib – 35 m	0.75	1.60	5.15					2.48	9.98	0.5
Jib – 30 m	0.75	1.60						2.48	4.83	0.3

Bolt table

Jib length	Brace	Bolts			Fuse	
		Quantity	Dimension [mm]	Item no.	Dimension [mm]	Item no.
Jibs - all	AL 7	1	Ø 105/90x235	30048840	Cotter pin 13 x 112	10006053
Jib – 70 m	1	1	Ø 80/70x200	30048828	Spring retainers 10/60-80	10022204
	2	3	Ø 80/70x200	30048828	Spring retainers 10/60-80	10022204
	3	2	Ø 80/70x200	30048828	Spring retainers 10/60-80	10022204
	4	1	Ø 80/70x200	30048828	Spring retainers 10/60-80	10022204
Jib – 65 m	1	1	Ø 80/70x200	30048828	Spring retainers 10/60-80	10022204
	2	3	Ø 80/70x200	30048828	Spring retainers 10/60-80	10022204
	3	1	Ø 80/70x200	30048828	Spring retainers 10/60-80	10022204
	4	1	Ø 80/70x200	30048828	Spring retainers 10/60-80	10022204
Jib – 60 m	1	1	Ø 80/70x200	30048828	Spring retainers 10/60-80	10022204
	2	2	Ø 80/70x200	30048828	Spring retainers 10/60-80	10022204
	3	2	Ø 80/70x200	30048828	Spring retainers 10/60-80	10022204
	4	1	Ø 80/70x200	30048828	Spring retainers 10/60-80	10022204
Jib – 55 m	1	1	Ø 80/70x200	30048828	Spring retainers 10/60-80	10022204
	2	2	Ø 80/70x200	30048828	Spring retainers 10/60-80	10022204
	3	1	Ø 80/70x200	30048828	Spring retainers 10/60-80	10022204
	4	1	Ø 80/70x200	30048828	Spring retainers 10/60-80	10022204
Jib – 50 m	1	1	Ø 80/70x200	30048828	Spring retainers 10/60-80	10022204
	2	1	Ø 80/70x200	30048828	Spring retainers 10/60-80	10022204
	3	2	Ø 80/70x200	30048828	Spring retainers 10/60-80	10022204
	4	1	Ø 80/70x200	30048828	Spring retainers 10/60-80	10022204
Jib – 45 m	1	1	Ø 80/70x200	30048828	Spring retainers 10/60-80	10022204
	2	1	Ø 80/70x200	30048828	Spring retainers 10/60-80	10022204
	3	1	Ø 80/70x200	30048828	Spring retainers 10/60-80	10022204

Jib length	Brace	Bolts			Fuse	
		Quantity	Dimension [mm]	Item no.	Dimension [mm]	Item no.
Jib – 45 m	4	1	Ø 80/70x200	30048828	Spring retainers 10/60-80	10022204
Jib – 40 m	1	1	Ø 80/70x200	30048828	Spring retainers 10/60-80	10022204
	2	-	Ø 80/70x200	30048828	Spring retainers 10/60-80	10022204
	3	2	Ø 80/70x200	30048828	Spring retainers 10/60-80	10022204
	4	1	Ø 80/70x200	30048828	Spring retainers 10/60-80	10022204
Jib – 35 m	1	1	Ø 80/70x200	30048828	Spring retainers 10/60-80	10022204
	2	-	Ø 80/70x200	30048828	Spring retainers 10/60-80	10022204
	3	1	Ø 80/70x200	30048828	Spring retainers 10/60-80	10022204
	4	1	Ø 80/70x200	30048828	Spring retainers 10/60-80	10022204
Jib – 30 m	1	1	Ø 80/70x200	30048828	Spring retainers 10/60-80	10022204
	2	-	Ø 80/70x200	30048828	Spring retainers 10/60-80	10022204
	3	-	Ø 80/70x200	30048828	Spring retainers 10/60-80	10022204
	4	1	Ø 80/70x200	30048828	Spring retainers 10/60-80	10022204

7.3 Arrangement of standard railings

7.3.1 Standard railings (NG) and accessories

Quant- ity	Standard railings (NG) / accessories	Article no.
3	Standard stays Ø42.4 x 1090	30000167
7	Standard railings NG 500	30018793
7	Standard railings NG 750	30018794
1	Standard railings NG 1000	30018795
4	Standard railings NG 1500	30018796
1	Standard railings NG 1500 S	30046289
3	Standard railings NG 2000	30018797

7.3.2 Arrangement of standard railings

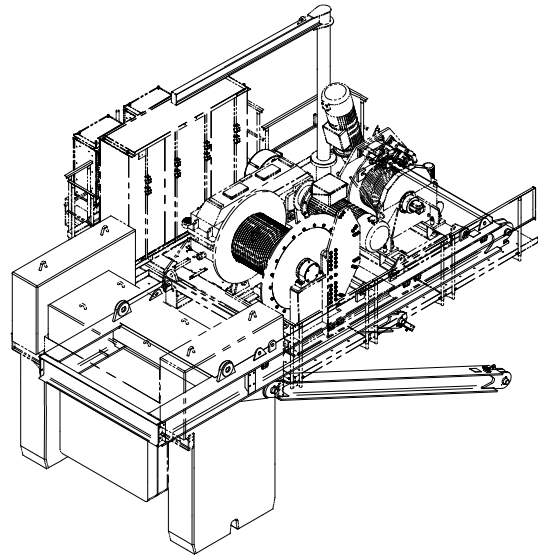
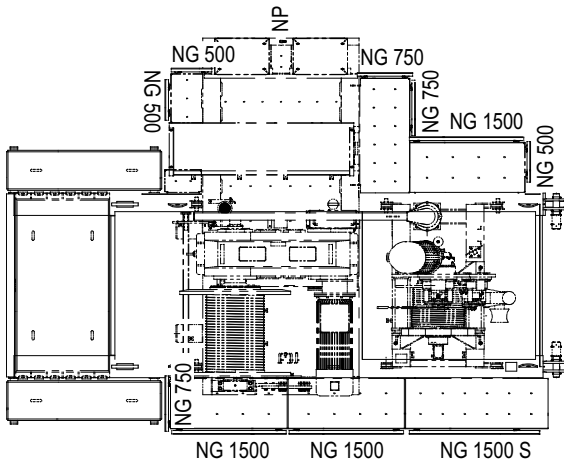

Arrangement of standard railings, counterjib

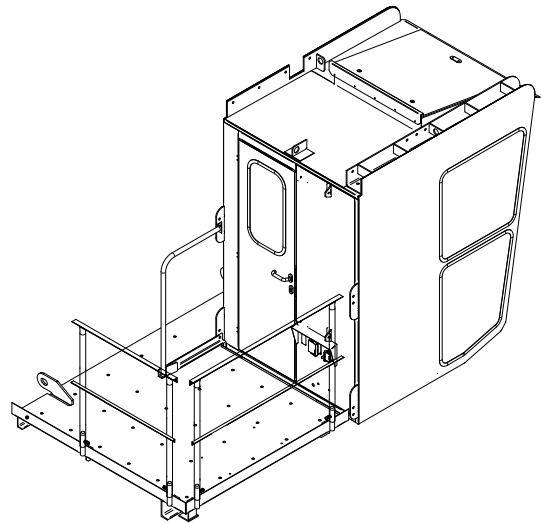
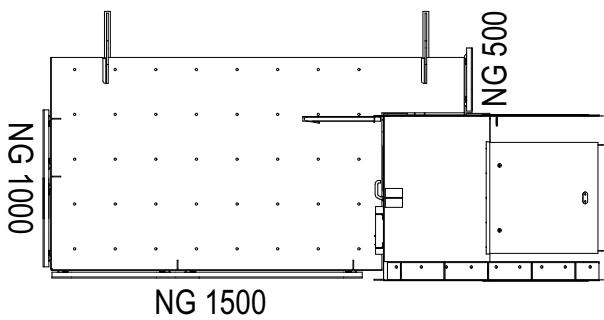

Arrangement of standard railings, operator cabin

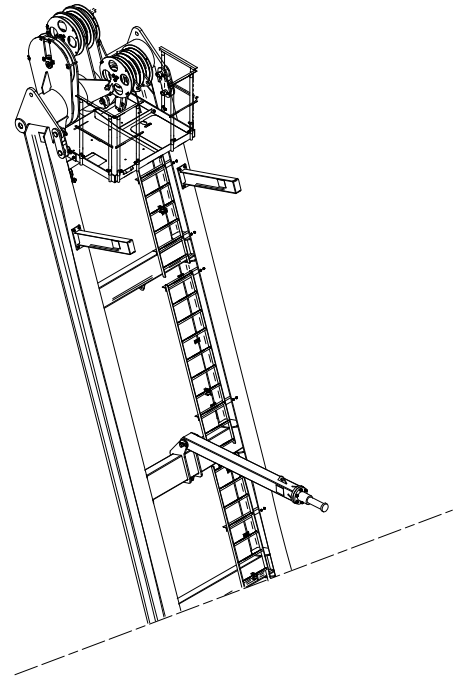
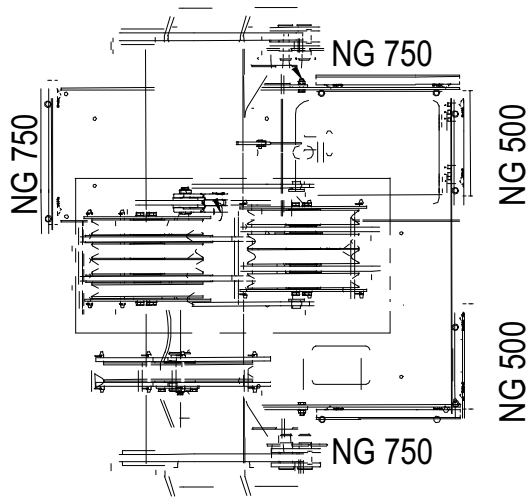

Arrangement of standard railings, tower head section

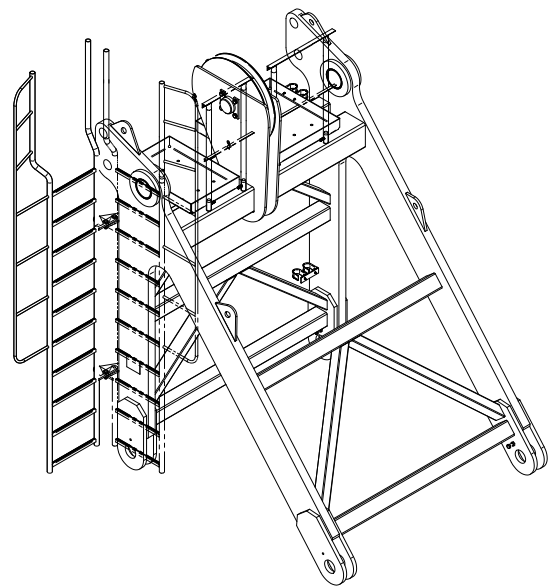
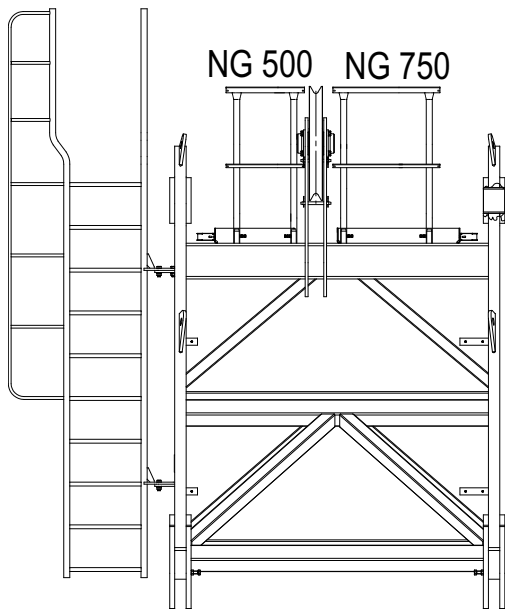

Arrangement of standard railings, connecting block

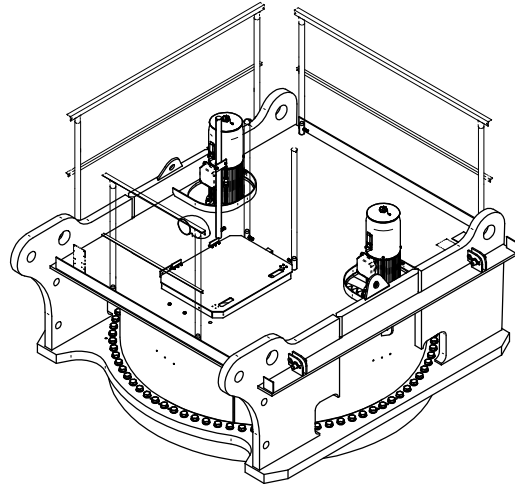
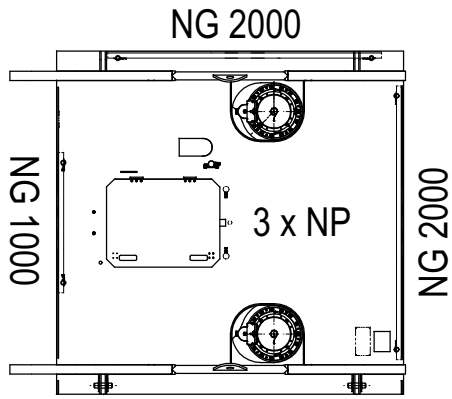



Arrangement of standard railings, slewing frame

8 Suitable climbing frames

This section contains information on

- Outer climbing units
- Inner climbing units (KSH)

	⚠ WARNING
	<p>Climbing unit attached to the cat head bottom section Increased wind surface. The slewing tower crane may overturn.</p> <ol style="list-style-type: none"> 1) Lower the climbing unit down on the tower, or 2) dismantle the climbing unit.

	NOTICE
	<p>Clamping forces for the inner climbing unit (KSH) are specified based on a building height of < 250m and wind category C 25</p>



	NOTICE
	<p>The operating radius specified is measured from the tower center and is to be considered a reference value. Exact balancing can be achieved by moving the trolley with the tower elements specified in the table or a load and can be checked by moving the end stops of the tower apart without offsets.</p>

	NOTICE
	<p>The data required and the instructions for tower assemblies with inner climbing unit is available in the separate description of the inner climbing unit.</p>

DANGER! Observe the special tower combination for the inner climbing unit.

	NOTICE
	<p>Details for climbing balancing</p> <p>The climbing balancing details obtain to the double reeving snatch block which includes that the Hook position is on the same height as at hook heights in height of the bottom edge of the tower head section lower part (hook height = tower height).</p>

8.1 Outer climbing units

	<p>NOTICE</p> <p>If feasible, you should preferably operate your climbing frame without balancing weight.</p>
	<p>NOTICE</p> <p>Tower element on the transfer carriage</p> <p>The data on climbing balance was specified under the assumption that a tower element is on the transfer carriage.</p>

8.1.1 Outer climbing unit KWH 23

Climbing radius [m] for the balancing weights

700B	Jib length [m]								
	70	65	60	55	50	45	40	35	30
no weight	35.6	37.8	38.8	41.3	42.1	-	-	-	-
HT 23 = 3.94 to	-	-	-	-	-	32.1	33.0	-	-
Weight t = 5.0 t	-	-	-	-	-	-	30.6	32.0	-
Weight t = 10.0 t	-	-	-	-	-	-	-	23.2	24.2

8.2 Inner climbing units

8.2.1 Internal climbing unit KSH 23/ KSH E 23

	NOTICE
	<p>Lower clamping length for the internal climbing unit KSH E 23</p> <p>Subject to coordination with WOLFFKRAN, it is also possible to realize a clamping length of 10.0 to 15.5 m with a lower tower height. Contact WOLFFKRAN to discuss this issue.</p>

Tower combinations for slewing tower cranes with internal climbing unit.

Item	Jib length 30 m - 60 m			
	1	HT 23	HT 23	HT 23
2	HT 23	HT 23	HT 23	HT 23
3	HT 23	HT 23	HT 23	HT 23
4	HT 23	HT 23	HT 23	HT 23
5	HT 23	HT 23	HT 23	HT 23
6	HT 23	HT 23	HT 23	
7	HT 23	HT 23		
8	HT 23			
internal climbing unit	KSH E 23	KSH E 23	KSH E 23	KSH E 23
Foundation	FUA G 210	FUA G 210	FUA G 210	FUA G 210
Tower height [m]	52.5	48.0	43.5	39.0

Tower combinations for slewing tower cranes with internal climbing unit.

Item	Jib length 65 m - 70 m			
	1	HT 23	HT 23	HT 23
2	HT 23	HT 23	HT 23	HT 23
3	HT 23	HT 23	HT 23	HT 23
4	HT 23	HT 23	HT 23	HT 23
5	HT 23	HT 23	HT 23	
6	HT 23	HT 23		
7	HT 23			
internal climbing unit	KSH E 23	KSH E 23	KSH E 23	KSH E 23
Foundation	FUA G 210	FUA G 210	FUA G 210	FUA G 210
Tower height [m]	48.0	43.5	39.0	34.5

Climbing radius for the balancing weights

700B	Jib length [m]				
	70	65	60	55	50
without weight	52.8	55.6	56.8	-	-
HT 23 = 3.94 t	-	-	42.9	44.7	46.3
Weight = 5.0 t	-	-	40.2	41.8	42.3
Weight = 10.0 t	-	-	-	-	-
Weight = 15.0 t	-	-	-	-	-

Climbing radius for the balancing weights

700B	Jib length [m]			
	45	40	35	30
without weight	-	-	-	-
HT 23 = 3.94 t	-	-	-	-
Weight = 5.0 t	-	-	-	-
Weight = 10.0 t	33.2	33.8	-	-
Weight = 15.0 t	-	-	27.6	28.4

The details obtain to the double reeving snatch block at hook heights in height of the bottom edge of the tower head section lower part (HH=TH)

WOLFFKRAN

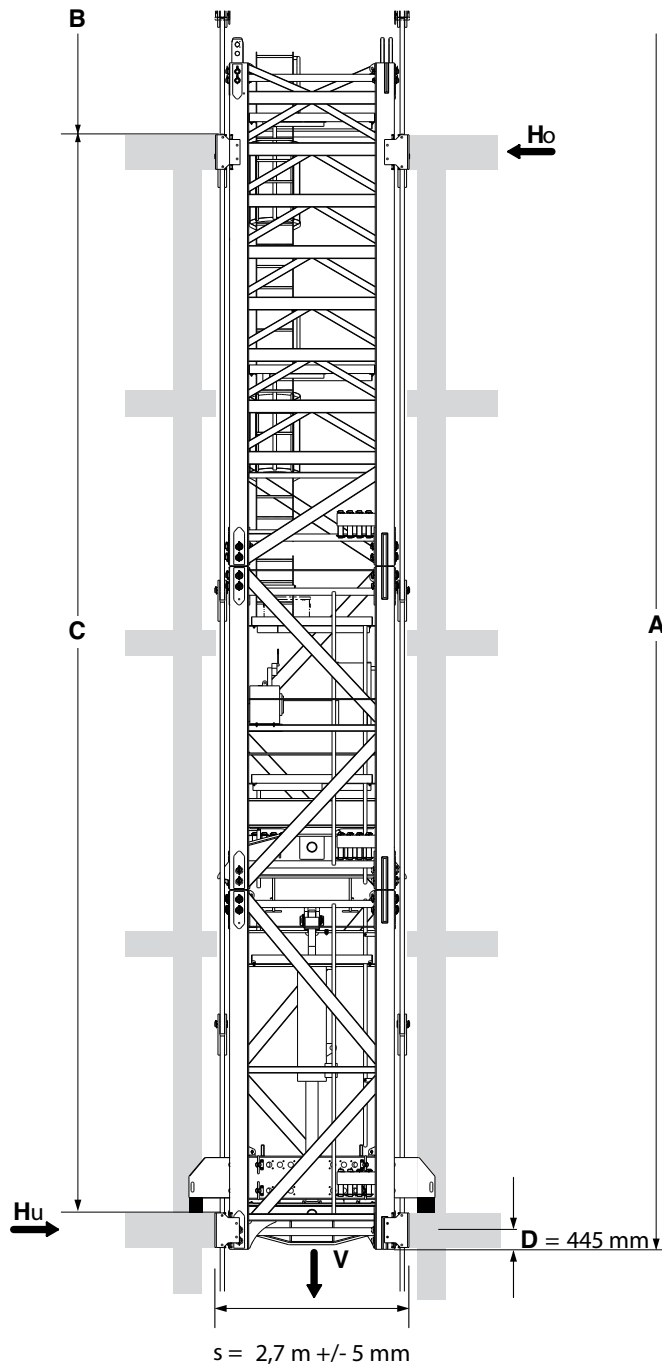

$$C_{\min} = 12,0 \text{ m}$$

$$C_{\max} = 15,5 \text{ m}$$

$$H_o = \frac{M}{C} + H$$

$$H_u = H_o - H$$

$$T = \frac{M_D}{2 \times b}$$

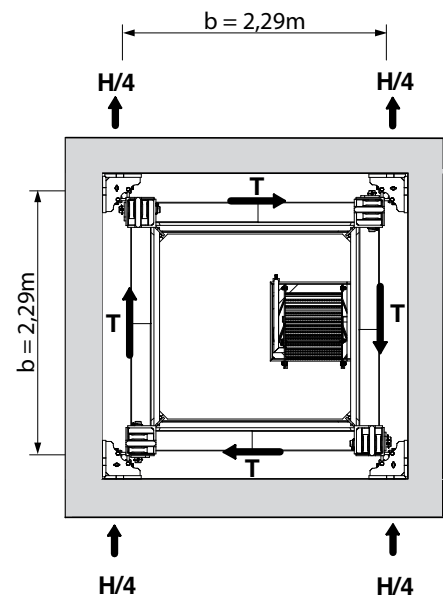

KSH E 23

A	= Tower height	C	= Distance between corner guides
W	= A-C-D		

WOLFFKRAN

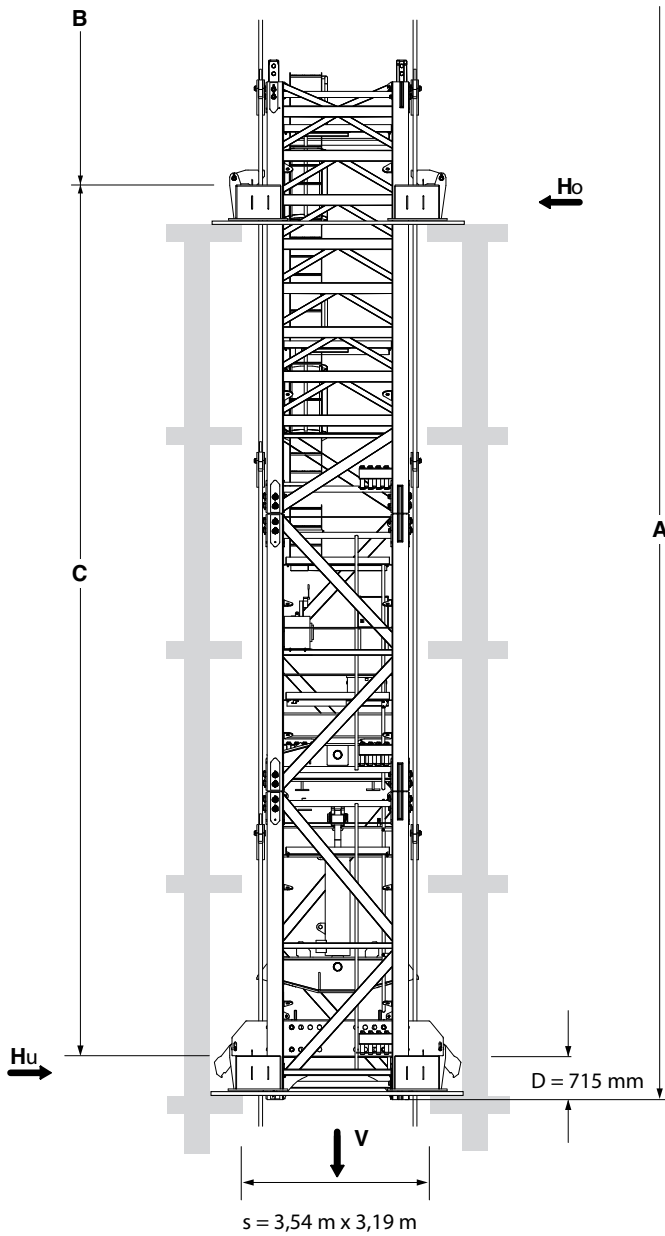

$$C_{\min} = 12,0 \text{ m}$$

$$C_{\max} = 15,5 \text{ m}$$

$$H_o = \frac{M}{C} + H$$

$$H_u = H_o - H$$

$$T = \frac{M_D}{2 \times b}$$

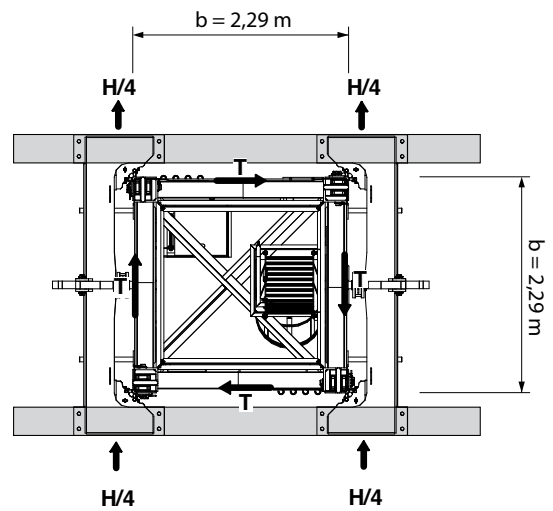

KSH 23

A	= Tower height	C	= Distance between climbing frames
W	= A-C-D		

Jib length 30 m - 60 m

Operational clamping forces [kN] inside a building																				
A (m)	52.5					48.0					43.5					39.0				
C (m)	12.0	13.0	14.0	15.0	15.5	12.0	13.0	14.0	15.0	15.5	12.0	13.0	14.0	15.0	15.5	12.0	13.0	14.0	15.0	15.5
V (kN)	2601					2561					2522					2483				
Ho (kN)	860	790	740	690	670	820	760	710	660	640	790	730	680	640	620	770	710	660	610	590
Hu (kN)	800	730	680	630	610	770	710	650	600	580	740	680	630	580	560	710	660	610	560	540
T (kN)	110					110					110					110				

Non-operational clamping forces [kN] inside a building																				
A (m)	52.5					48.0					43.5					39.0				
C (m)	12.0	13.0	14.0	15.0	15.5	12.0	13.0	14.0	15.0	15.5	12.0	13.0	14.0	15.0	15.5	12.0	13.0	14.0	15.0	15.5
V (kN)	2073					2034					1994					1955				
Ho (kN)	1320	1220	1130	1060	1020	1180	1090	1020	950	920	1060	980	910	850	820	940	870	810	760	730
Hu (kN)	970	870	780	710	670	850	760	680	610	580	740	660	590	530	500	640	570	500	450	430
T (kN)	-					-					-					-				

Jib length 65 m - 70 m

Operational clamping forces [kN] inside a building																				
A (m)	48.0					43.5					39.0					34.5				
C (m)	12.0	13.0	14.0	15.0	15.5	12.0	13.0	14.0	15.0	15.5	12.0	13.0	14.0	15.0	15.5	12.0	13.0	14.0	15.0	15.5
V (kN)	2384					2345					2305					2266				
Ho (kN)	820	760	710	660	640	790	730	680	630	610	760	700	650	610	590	730	670	630	590	570
Hu (kN)	760	690	640	590	570	730	660	610	570	550	700	640	590	550	530	670	610	570	520	510
T (kN)	110					110					110					110				

Non-operational clamping forces [kN] inside a building																				
A (m)	48.0					43.5					39.0					34.5				
C (m)	12.0	13.0	14.0	15.0	15.5	12.0	13.0	14.0	15.0	15.5	12.0	13.0	14.0	15.0	15.5	12.0	13.0	14.0	15.0	15.5
V (kN)	2058					2019					1980					1940				
Ho (kN)	1380	1270	1180	1100	1070	1250	1150	1070	1000	970	1130	1040	970	900	880	1020	940	870	820	790
Hu (kN)	1040	930	840	770	730	930	830	750	680	650	820	730	660	600	570	720	650	580	520	500
T (kN)	-					-					-					-				

9 Arrangement of counterweight blocks

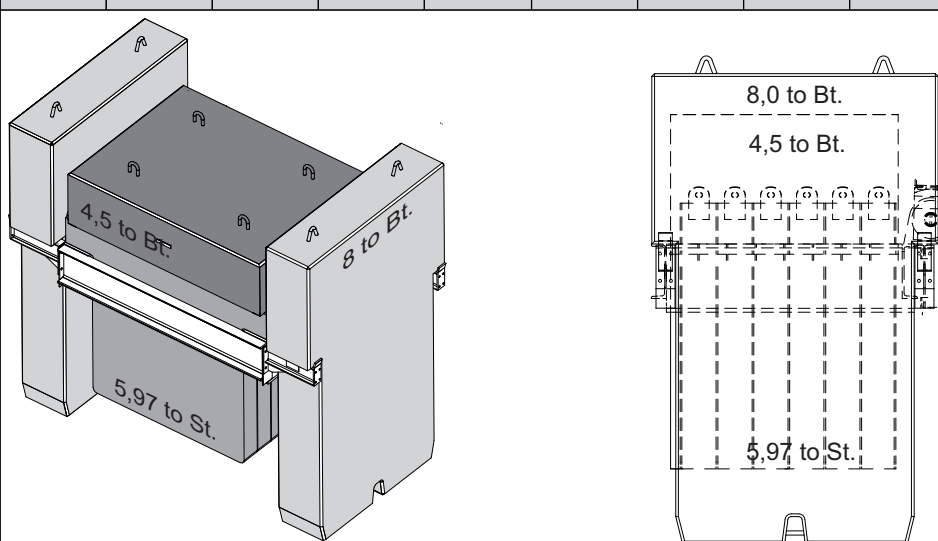
Jib length [m]	70	65	60	55	50	45	40	35	30
Total weight 56.32 t	 <p>The 3D perspective view shows three counterweight blocks: a top block labeled '4,5 to Bt.', a middle block labeled '5,97 to St.', and a bottom block labeled '8 to Bt.'. The top-down view shows a rectangular arrangement of blocks with labels: '8,0 to Bt.' at the top, '4,5 to Bt.' in the middle, and '5,97 to St.' at the bottom.</p>								
									6 x 5.97 tons suspended steel weight
									2 x 8.0 tons suspended concrete weight
									1 x 4.5 tons lying concrete weight

