



AC 40 City | All Terrain Crane 45 t Lifting Capacity



AC 40 City

ALL TERRAIN CRANE

AC 40 City
HIGHLIGHTS

- ▶ Most compact 3-axle crane in its category
- ▶ Fast on the road and exceptionally maneuverable off road
- ▶ Clearance height is just 9.8 ft
- ▶ Runner for indoor applications

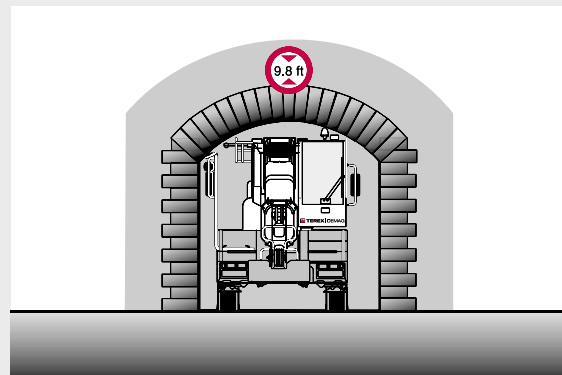
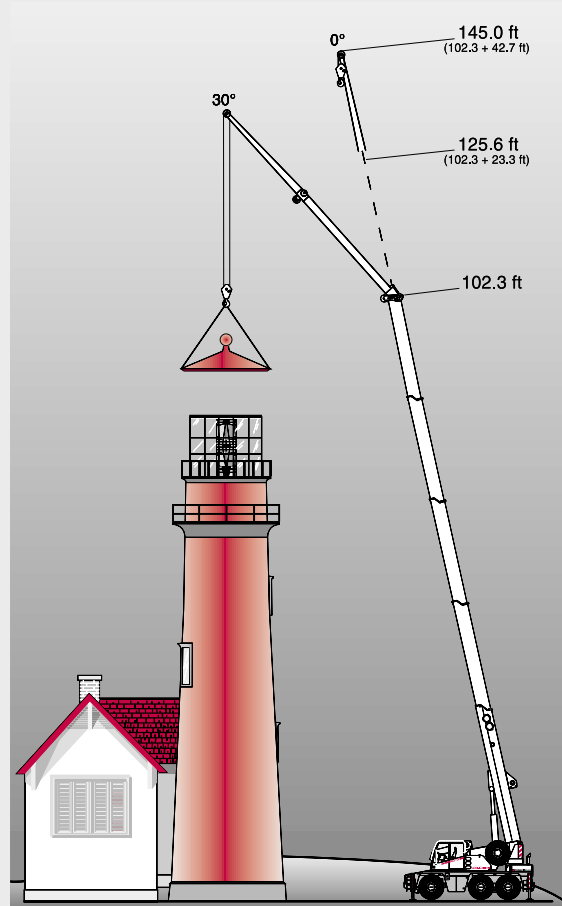

CONTENTS

Page:

Specifications

Dimensions	4
Specifications	6

1

Main boom

Working ranges	7
Lifting capacities	8

2

Main boom extension

Working ranges	10
Lifting capacities	11

3

Runner

Runner for workshop applications	12
Lifting capacities	13
Runner and searcher hook for workshop applications	14

4

Technical description

Carrier · Superstructure · Optional equipment	15
---	----

5

DIMENSIONS

TYPE OF TIRES

	Level	A	B	C	D
14.00 R 25 17.50 R 25	Road	10'5"	10'1"	1'2"	4'9"
14.00 R 25 17.50 R 25	Lowered	10'2"	9'9"	9"	4'6"
445 / 65 R 22.5	Road	10'1"	9'8"	8"	4'5"
445 / 65 R 22.5	Lowered	9'8"	9'5"	5"	4'2"

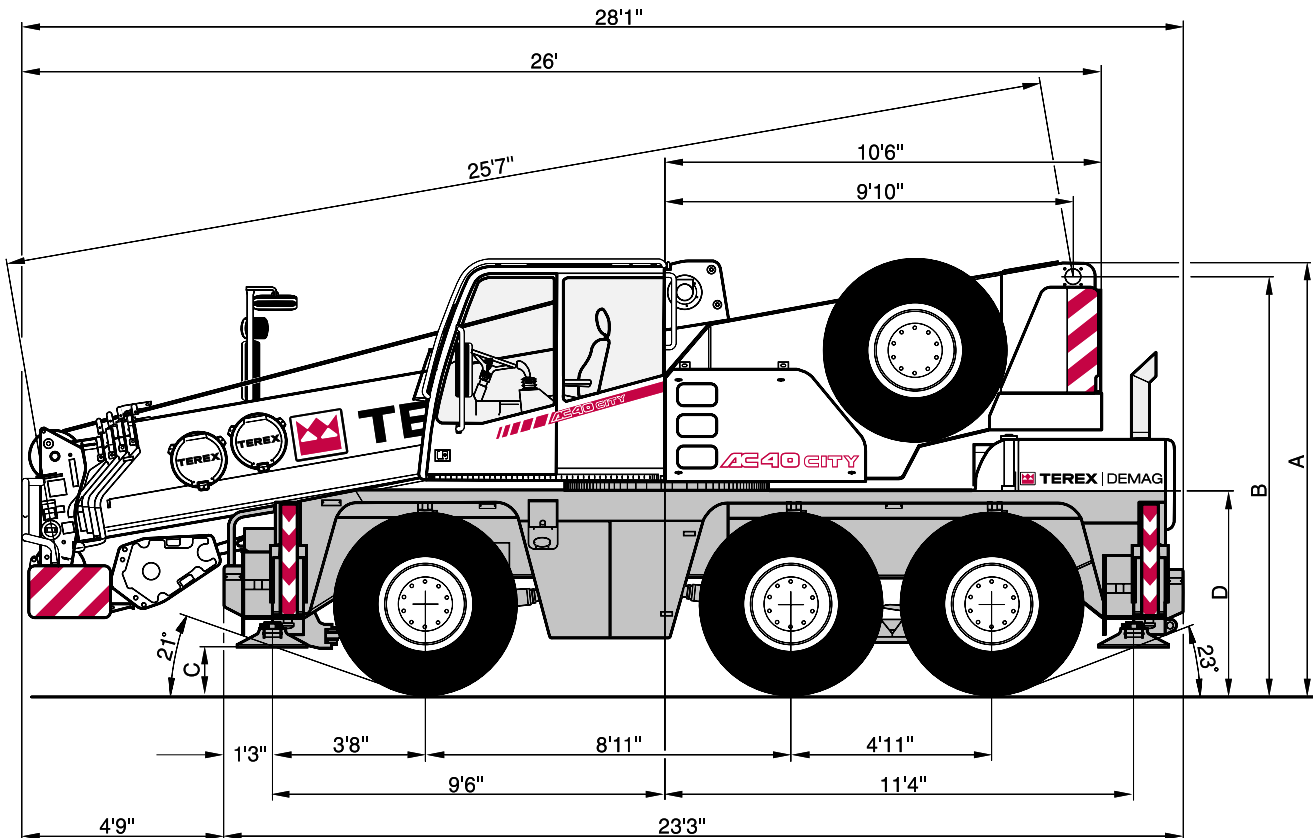

DIMENSIONS

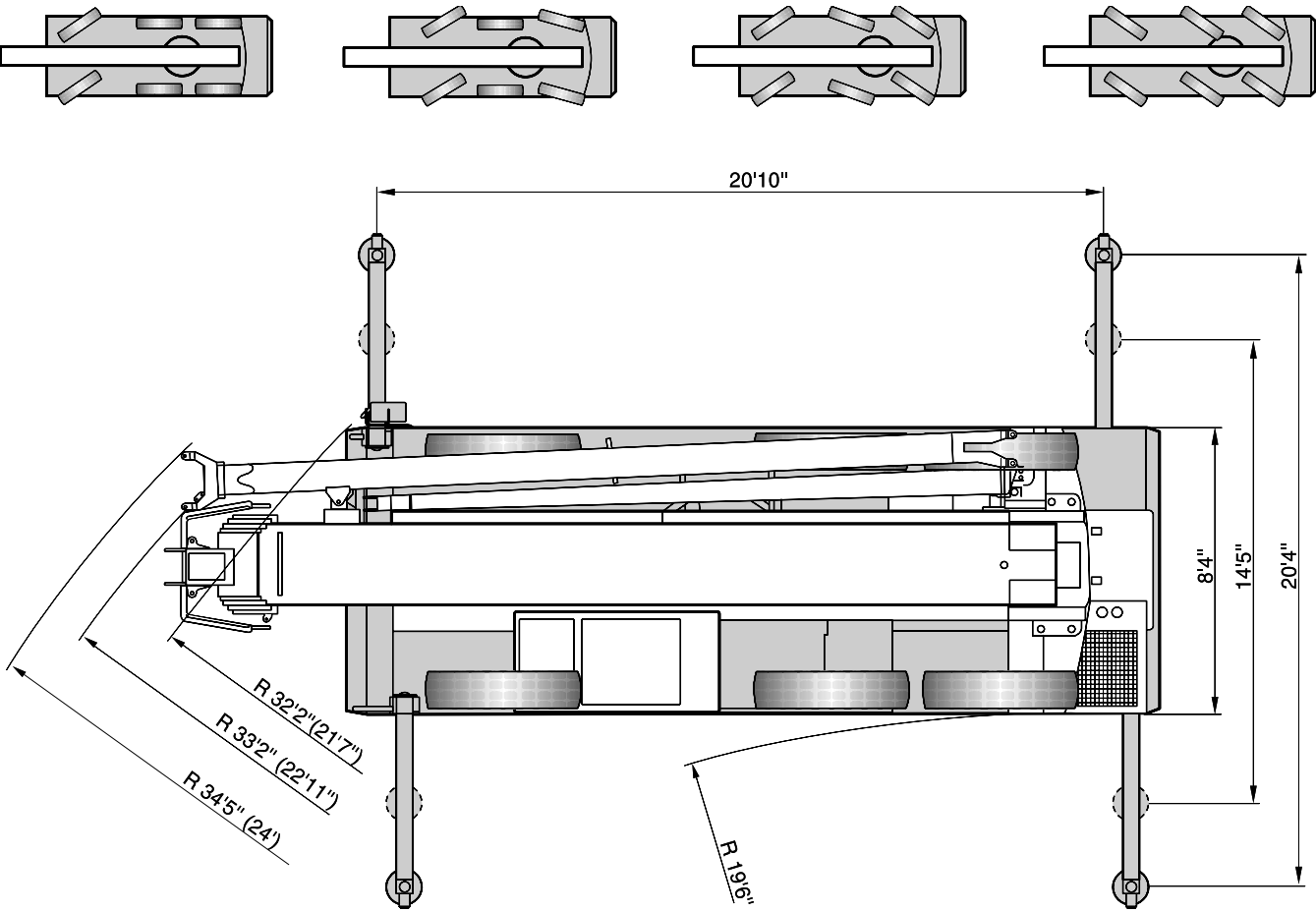

() with independent rear axle steering

SPECIFICATIONS

AXLE LOADS

Crane with main boom, 42.6 ft main boom extension, counterweight, tires 445/65 R 22.5, hook block.

Axles	Axle 1	20,000 lb
	Axle 2+3	25,000 lb
Total		70,000 lb

WORKING SPEEDS (INFINITELY VARIABLE)

Mechanisms	Normal speed	High speed	Max. permissible line pull ¹⁾	Rope length
Hoist I	197 ft / min	377 ft / min	9,400 lb	492.1 ft
Slewing				max. 2 1/min
Telescoping speed				25.6 – 102.3 ft: 90 s
Boom elevation				-10° – +78°: 50 s

CARRIER PERFORMANCE

Travel speed	0 . . 50 mph ²⁾
Gradeability in travel order	> 60 %
Ground clearance	1' / 1'3" ft ²⁾

HOOK BLOCK / SINGLE LINE HOOK

Type	Possible load ¹⁾	Number of sheaves	Weight	„D“	Number of lines	Heavy-lift attachment
63	110,000 lb	6	1,058 lb	6.6 ft	10	1 add'l. sheave
32	66,400 lb	3	716 lb	4.3 ft	7	
16	26,500 lb	1	551 lb	3.6 ft	3	
5	8,800 lb	Single line hook	287 lb	2.6 ft	1	

Remarks



¹⁾ varies depending on national regulations

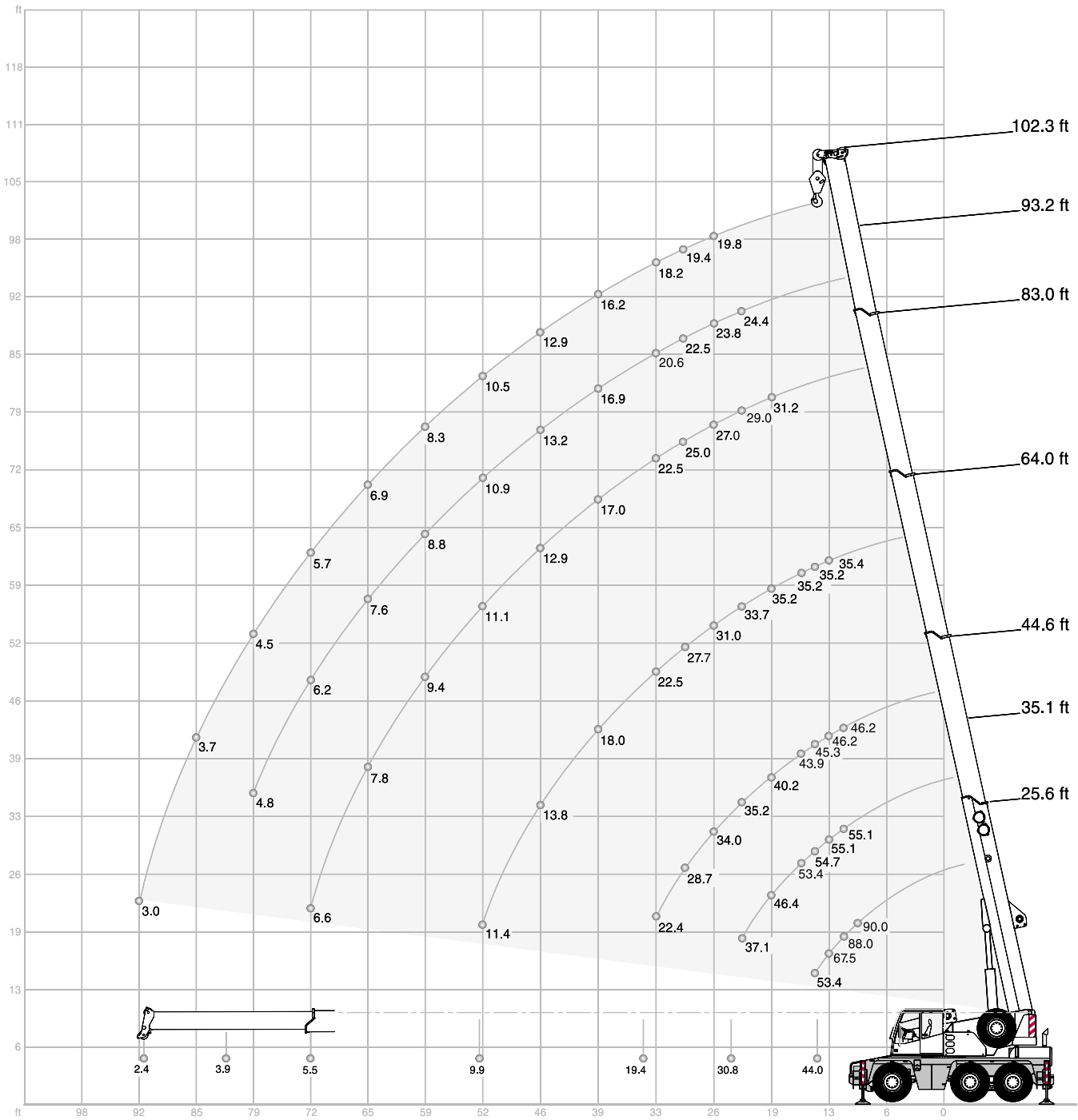

²⁾ depending on type of tires

WORKING RANGES MAIN BOOM



LIFTING CAPACITIES MAIN BOOM

 20'10" x 20'4" 360° DIN/ISO									 0°* DIN/ISO				
Radius	ft	Main boom							Main boom				
		25.6	35.1	44.6	64.0	83.0	93.2	102.3	25.6	35.1	44.6	Radius	
ft		1,000 lb							1,000 lb				ft
8	90.0*	-	-	-	-	-	-	-	-	-	-	8	
10	88.0*	-	-	-	-	-	-	-	-	-	10		
10	75.2	55.1	46.2	-	-	-	-	-	31.6	30.5	32.9	10	
11	72.6	55.1	46.2	-	-	-	-	-	29.4	28.3	30.6	11	
13	67.5	55.1	46.2	35.4	-	-	-	-	25.5	24.6	26.8	13	
15	53.4	54.7	45.3	35.2	-	-	-	-	19.6	21.7	23.9	15	
16	-	53.4	43.9	35.2	-	-	-	-	-	20.3	22.5	16	
19	-	46.4	40.2	35.2	31.2	-	-	-	-	17.2	19.2	19	
23	-	37.1	35.2	33.7	29.0	24.4	-	-	-	13.3	15.8	23	
26	-	-	34.0	31.0	27.0	23.8	19.8	-	-	-	13.2	26	
29	-	-	28.7	27.7	25.0	22.5	19.4	-	-	-	10.9	29	
33	-	-	22.4	22.5	22.5	20.6	18.2	-	-	-	9.0	33	
39	-	-	-	18.0	17.0	16.9	16.2	-	-	-	-	39	
46	-	-	-	13.8	12.9	13.2	12.9	-	-	-	-	46	
52	-	-	-	11.4	11.1	10.9	10.5	-	-	-	-	52	
59	-	-	-	-	9.4	8.8	8.3	-	-	-	-	59	
65	-	-	-	-	7.8	7.6	6.9	-	-	-	-	65	
72	-	-	-	-	6.6	6.2	5.7	-	-	-	-	72	
79	-	-	-	-	-	4.8	4.5	-	-	-	-	79	
85	-	-	-	-	-	-	3.7	-	-	-	-	85	
92	-	-	-	-	-	-	3.0	-	-	-	-	92	
Capacities ¹⁾	44.0	30.8	19.4	9.9	5.5	3.9	2.4		17.6	8.8	6.6	Capacities ¹⁾	

 20'10" x 7'8" 360° DIN/ISO						 360°** DIN/ISO				
Radius	ft	Main boom				Main boom				
		25.6	35.1	44.6	64.0	25.6	35.1	44.6	Radius	
ft		1,000 lb				1,000 lb				ft
13		26.5	25.0	28.1	28.7	-	-	-	13	
15		18.5	19.8	22.6	23.3	11.1	11.6	14.2	15	
16		-	17.7	20.4	21.1	-	10.7	13.2	16	
19		-	13.4	15.7	16.4	-	8.4	10.8	19	
23		-	9.3	11.6	12.1	-	6.1	8.3	23	
26		-	-	9.6	10.0	-	-	6.9	26	
29		-	-	8.1	8.6	-	-	5.9	29	
33		-	-	6.4	6.9	-	-	4.8	33	
39		-	-	-	5.1	-	-	-	39	
46		-	-	-	3.7	-	-	-	46	
52		-	-	-	2.9	-	-	-	52	
Capacities ¹⁾		17.6	6.1	4.6	-	10.6	4.2	2.9	Capacities ¹⁾	

Remarks

- * 0° over rear
- ** only stationary
- 1) with horizontal boom

LIFTING CAPACITIES MAIN BOOM

 20'10" x 14'5"

360°

DIN/ISO

Radius	ft	Main boom							Radius
		25.6	35.1	44.6	64.0	83.0	93.2	102.3	
ft					1,000 lb				ft
10		74.9	55.1	46.2	-	-	-	-	10
11		70.7	55.1	46.2	-	-	-	-	11
13		62.8	55.1	46.2	35.4	-	-	-	13
15		44.9	49.2	44.7	35.2	-	-	-	15
16		-	43.0	41.1	35.2	-	-	-	16
19		-	31.1	32.4	32.1	31.2	-	-	19
23		-	21.3	24.4	25.0	23.9	23.7	-	23
26		-	-	19.9	20.6	19.5	19.5	19.6	26
29		-	-	16.6	17.3	17.2	16.8	16.4	29
33		-	-	13.2	14.0	14.2	13.7	13.3	33
39		-	-	-	10.7	11.0	10.5	10.1	39
46		-	-	-	8.1	8.3	7.9	7.4	46
52		-	-	-	6.7	6.7	6.3	6.0	52
59		-	-	-	-	5.5	5.0	4.6	59
65		-	-	-	-	4.7	4.0	3.8	65
72		-	-	-	-	3.7	3.3	2.8	72
79		-	-	-	-	-	2.6	2.1	79
85		-	-	-	-	-	-	1.7	85
92		-	-	-	-	-	-	1.3	92
Capacities ¹⁾		44.1	15.4	11.4	5.5	3.3	1.7	-	Capacities ¹⁾

Remarks

¹⁾ with horizontal boom

WORKING RANGES MAIN BOOM EXTENSION

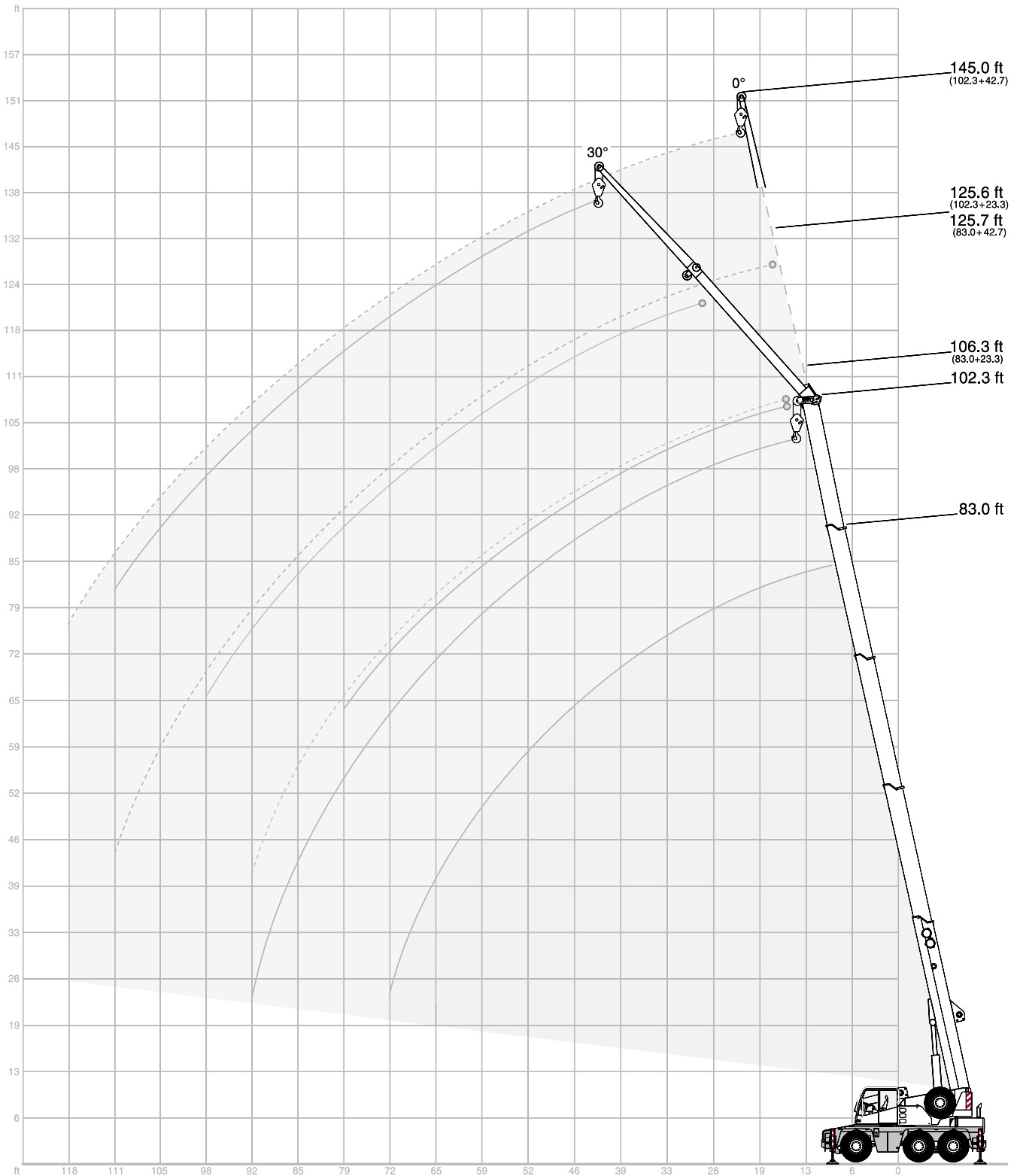

LIFTING CAPACITIES MAIN BOOM EXTENSION

		20'10" x 20'4"		360°		DIN/ISO	
83.0 ft	Main boom	Extension					
		23.3 ft		42.7 ft			
		0°	30°	0°	30°		
ft		1,000 lb					
26		14.3	-	-	-	-	-
29		13.7	-	-	-	-	-
33		12.9	9.2	7.9	-	-	-
39		11.9	8.8	7.3	-	-	-
46		10.7	8.3	6.6	-	-	-
52		9.9	8.1	6.2	4.8	-	-
59		8.8	7.7	5.7	4.6	-	-
65		7.4	7.5	5.3	4.4	-	-
72		6.2	6.4	5.0	4.1	-	-
79		5.0	5.2	4.6	4.1	-	-
85		4.2	-	4.4	3.9	-	-
92		3.5	-	3.7	3.9	-	-
98		-	-	3.3	3.5	-	-
105		-	-	2.6	-	-	-
111		-	-	2.2	-	-	-

		20'10" x 14'5"		360°		DIN/ISO	
83.0 ft	Main boom	Extension					
		23.3 ft		42.7 ft			
		0°	30°	0°	30°		
ft		1,000 lb					
26		14.3	-	-	-	-	-
29		13.7	-	-	-	-	-
33		12.9	9.2	7.9	-	-	-
39		10.5	8.8	7.3	-	-	-
46		7.9	8.3	6.6	-	-	-
52		6.3	6.9	6.2	4.8	-	-
59		5.0	5.5	5.2	4.6	-	-
65		4.0	4.5	4.2	4.4	-	-
72		3.3	3.5	3.5	4.1	-	-
79		2.6	2.8	2.8	3.5	-	-
85		2.0	-	2.2	2.8	-	-
92		1.5	-	1.7	2.1	-	-
98		-	-	1.3	1.7	-	-
105		-	-	-	-	-	-
111		-	-	-	-	-	-

		23.3 ft		42.7 ft			
102.3 ft	Main boom	Extension					
		0°	30°	0°	30°		
		ft	1,000 lb				
33		11.0	-	-	-	-	-
39		10.6	8.6	6.6	-	-	-
46		10.1	8.1	6.3	-	-	-
52		9.7	7.7	6.1	-	-	-
59		8.8	7.2	5.9	4.6	-	-
65		7.4	6.8	5.5	4.4	-	-
72		5.9	6.4	5.2	4.1	-	-
79		4.8	5.2	4.8	4.1	-	-
85		4.0	4.4	4.2	3.9	-	-
92		3.2	3.5	3.5	3.9	-	-
98		2.6	2.9	2.9	3.5	-	-
105		1.9	-	2.4	2.8	-	-
111		1.5	-	2.0	2.2	-	-
118		-	-	1.5	-	-	-
124		-	-	-	-	-	-

		23.3 ft		42.7 ft			
102.3 ft	Main boom	Extension					
		0°	30°	0°	30°		
		ft	1,000 lb				
33		10.9	-	-	-	-	-
39		10.1	8.6	6.6	-	-	-
46		7.7	8.1	6.3	-	-	-
52		6.2	6.9	6.1	-	-	-
59		4.8	5.5	5.0	4.6	-	-
65		3.8	4.5	4.0	4.4	-	-
72		3.1	3.5	3.3	3.9	-	-
79		2.3	2.8	2.6	3.2	-	-
85		1.7	2.2	2.0	2.6	-	-
92		1.3	1.5	1.5	2.1	-	-
98		-	-	-	1.5	-	-
105		-	-	-	-	-	-
111		-	-	-	-	-	-
118		-	-	-	-	-	-
124		-	-	-	-	-	-

3

RUNNER FOR WORKSHOP APPLICATIONS

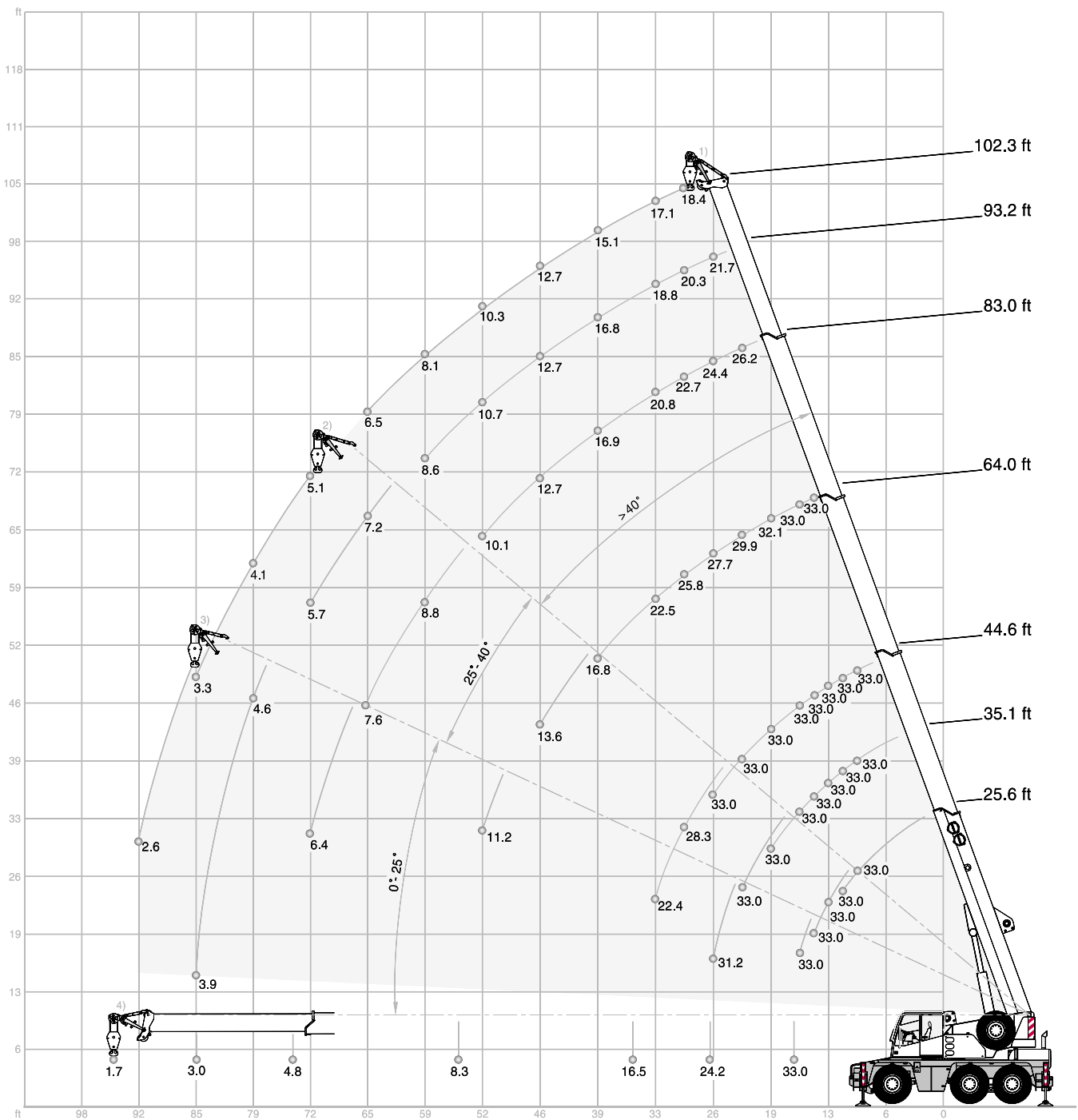

LIFTING CAPACITIES RUNNER

 20'10" x 20'4"

360°

DIN/ISO

Radius	ft	Main boom							Radius
		25.6	35.1	44.6	64.0	83.0	93.2	102.3	
ft					1,000 lb				ft
10		33.0 ¹⁾	33.0 ¹⁾	33.0 ¹⁾	-	-	-	-	10
11		33.0 ¹⁾	33.0 ¹⁾	33.0 ¹⁾	-	-	-	-	11
13		33.0 ²⁾	33.0 ¹⁾	33.0 ¹⁾	-	-	-	-	13
15		33.0 ²⁾	33.0 ¹⁾	33.0 ¹⁾	33.0 ¹⁾	-	-	-	15
16		33.0 ³⁾	33.0 ¹⁾	33.0 ¹⁾	33.0 ¹⁾	-	-	-	16
19		-	33.0 ¹⁾	33.0 ¹⁾	32.1 ¹⁾	-	-	-	19
23		-	33.0 ²⁾	33.0 ¹⁾	29.9 ¹⁾	26.2 ¹⁾	-	-	23
26		-	31.2 ³⁾	33.0 ¹⁾	27.7 ¹⁾	24.4 ¹⁾	21.7 ¹⁾	-	26
29		-	-	28.3 ²⁾	25.8 ¹⁾	22.7 ¹⁾	20.3 ¹⁾	18.4 ¹⁾	29
33		-	-	22.4 ²⁾	22.5 ¹⁾	20.8 ¹⁾	18.8 ¹⁾	17.1 ¹⁾	33
39		-	-	-	16.8 ¹⁾	16.9 ¹⁾	16.8 ¹⁾	15.1 ¹⁾	39
46		-	-	-	13.6 ²⁾	12.7 ¹⁾	12.7 ¹⁾	12.7 ¹⁾	46
52		-	-	-	11.2 ³⁾	10.1 ¹⁾	10.7 ¹⁾	10.3 ¹⁾	52
59		-	-	-	-	8.8 ²⁾	8.6 ¹⁾	8.1 ¹⁾	59
65		-	-	-	-	7.6 ²⁾	7.2 ²⁾	6.5 ¹⁾	65
72		-	-	-	-	6.4 ³⁾	5.7 ²⁾	5.1 ²⁾	72
79		-	-	-	-	-	4.6 ³⁾	4.1 ²⁾	79
85		-	-	-	-	-	3.9 ³⁾	3.3 ²⁾	85
92		-	-	-	-	-	-	2.6 ³⁾	92
Capacities ⁴⁾		33.0 ²⁺³⁾	24.2 ²⁺³⁾	16.5 ²⁺³⁾	8.3 ²⁺³⁾	4.8 ²⁺³⁾	3.0 ²⁺³⁾	1.7 ²⁺³⁾	Capacities ⁴⁾

 20'10" x 14'5"

360°

DIN/ISO

Radius	ft	Main boom							Radius
		25.6	35.1	44.6	64.0	83.0	93.2	102.3	
ft					1,000 lb				ft
10		33.0 ¹⁾	33.0 ¹⁾	33.0 ¹⁾	-	-	-	-	10
11		33.0 ¹⁾	33.0 ¹⁾	33.0 ¹⁾	-	-	-	-	11
13		33.0 ²⁾	33.0 ¹⁾	33.0 ¹⁾	-	-	-	-	13
15		33.0 ²⁾	33.0 ¹⁾	33.0 ¹⁾	33.0 ¹⁾	-	-	-	15
16		33.0 ³⁾	33.0 ¹⁾	33.0 ¹⁾	33.0 ¹⁾	-	-	-	16
19		-	30.1 ¹⁾	32.5 ¹⁾	32.0 ¹⁾	-	-	-	19
23		-	21.9 ²⁾	24.6 ¹⁾	24.1 ¹⁾	24.1 ¹⁾	-	-	23
26		-	17.7 ³⁾	20.0 ¹⁾	20.5 ¹⁾	19.5 ¹⁾	19.4 ¹⁾	-	26
29		-	-	16.8 ²⁾	17.3 ¹⁾	16.4 ¹⁾	16.5 ¹⁾	16.2 ¹⁾	29
33		-	-	13.2 ²⁾	14.0 ¹⁾	14.2 ¹⁾	13.5 ¹⁾	13.1 ¹⁾	33
39		-	-	-	10.5 ¹⁾	10.7 ¹⁾	10.3 ¹⁾	9.6 ¹⁾	39
46		-	-	-	7.9 ²⁾	8.1 ¹⁾	7.6 ¹⁾	7.2 ¹⁾	46
52		-	-	-	6.5 ³⁾	6.5 ¹⁾	6.0 ¹⁾	5.6 ¹⁾	52
59		-	-	-	-	5.3 ²⁾	4.6 ¹⁾	4.2 ¹⁾	59
65		-	-	-	-	4.2 ²⁾	3.8 ²⁾	3.3 ¹⁾	65
72		-	-	-	-	3.5 ³⁾	2.8 ²⁾	2.4 ²⁾	72
79		-	-	-	-	-	2.3 ³⁾	1.7 ²⁾	79
85		-	-	-	-	-	1.7 ³⁾	-	85
92		-	-	-	-	-	-	-	92
Capacities ⁴⁾		33.0 ²⁺³⁾	14.9 ²⁺³⁾	10.5 ²⁺³⁾	5.0 ²⁺³⁾	2.6 ²⁺³⁾	-	-	Capacities ⁴⁾

Remarks

- 1) Working range – max. offset for runner
- 2) Working range – medium offset for runner
- 3) Working range – min. offset for runner
- 4) with horizontal boom

RUNNER AND SEARCHER HOOK FOR WORKSHOP APPLICATIONS

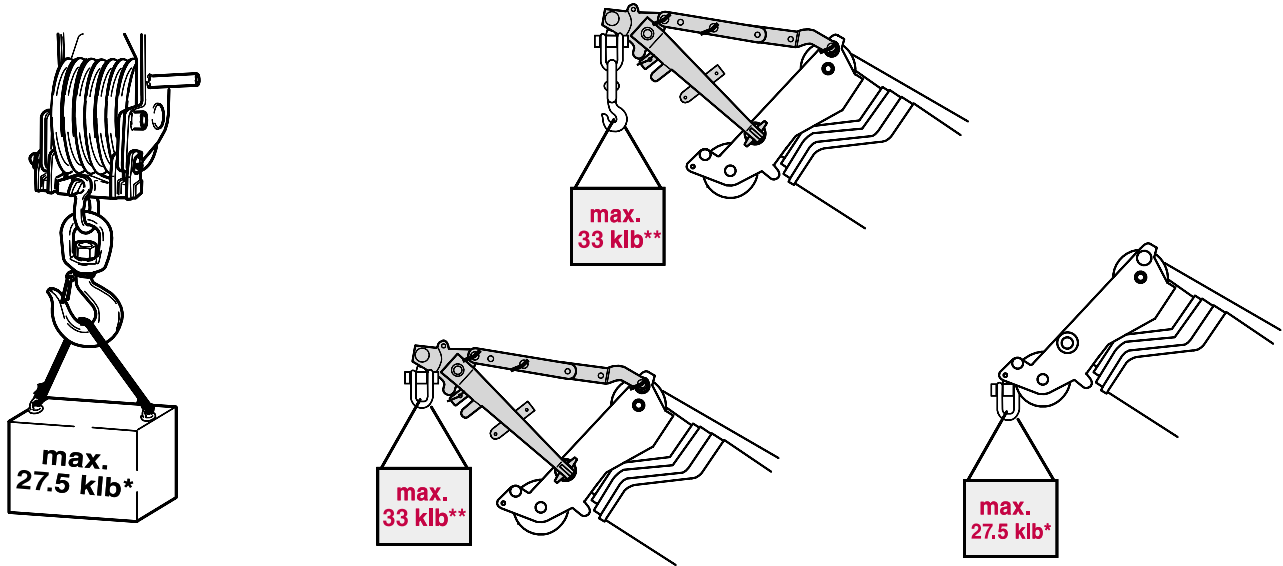

* Main boom duties apply until the maximum loads specified above have been achieved

** Runner charts apply

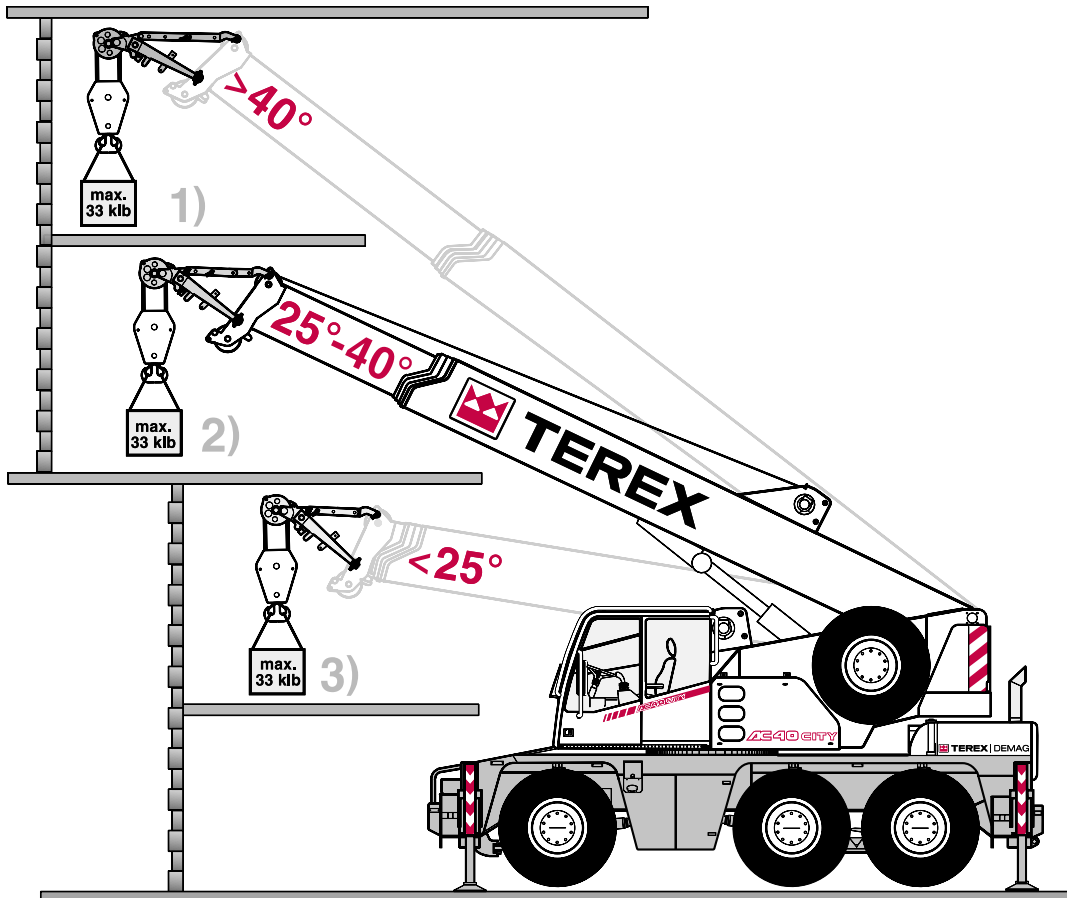

TECHNICAL DESCRIPTION

CARRIER

Drive / steering	6 x 4 x 6.
Frame	Monobox main frame with outrigger boxes integral, of high-strength fine-grain structural steel.
Outriggers	4 hydraulically telescoping outrigger beams with hydraulic jack legs.
Engine	DaimlerChrysler OM 906 LA water-cooled 6-cylinder engine, output to DIN: 205 kW (279 HP), max. torque 1100 Nm at 1300 1/min. Fuel tank capacity: 79 gallons.
Transmission	Allison automatic transmission with torque-converter, 6 forward speeds and 1 reverse, transfer case with off-road range and longitudinal differential lock-out control incl. ADM.
Axles	Axle 1: with ext. planetary hubs, steering, transverse differential locks; axle 2: non-driving, steering for crab steer mode; axle 3: with ext. planetary hubs, steering for crab steer mode, transverse differential locks.
Suspension	Hydropneumatic suspension, blockable hydraulically.
Wheels and tires	6 wheels fitted with 445/65 R 22.5 tires.
Travel speed	50 mph.
Steering	ZF dual-circuit hydraulic steering with mech. steering end stop. 1 engine-driven master steering pump, 1 emergency steering pump. Independent, electronic-hydraulic rear axle steering.
Brakes	Service brake: dual-line air system. Parking brake: spring-loaded type. Sustained action brake: engine exhaust brake and constant decompression valve. ABS as standard.
Electrical equipment	24 V system, 3-phase alternator 80 A, 2 batteries 12 V / 120 Ah. Lighting in compliance with EC-directives.

SUPERSTRUCTURE

Main boom	Boom base and four telescopic sections, fabricated from fine-grain structural steel, telescoping with partial load, anti-deflection Demag ovaloid design.
Counterweight	Integrated into superstructure.
Hydraulic system	Powered by carrier engine, 1 variable-displacement axial piston pump to enable 3 simultaneous, independent working movements, separate fixed-displacement pump for slew unit.
Hoist	Fixed-displacement axial-piston motor, hoist drum with planetary reduction integral and spring-applied multi-disk brake.
Slew unit	Hydraulic motor with planetary gear reducer, pedal-operated service brake and spring-applied holding brake. Slewing speed infinitely variable.
Boom elevation	1 differential cylinder with pilot-controlled lowering brake valve.
Crane cab	Spacious all-steel comfortable cab with sliding door, large folding-out windscreen, roof window with armoured glass, air-sprung and heated driver's seat, controls and instrumentation for all crane movements, washer and interval control wiper for windscreen and roof window, electrically adjustable and heated outside mirrors, air-conditioning as standard.
Safety devices	Electronic safe load indicator with graphic display and digital readout for hook load, rated load, boom length, boom angle, load radius. Integrated display to indicate the percentage of tele sequence, limit switches on hoist and lowering motions, pressure-relief and safety holding valves.

OPTIONAL EQUIPMENT

Drive / steering	6 x 6 x 6.
Wheels and tires	14.00 R 25 or 17.5 R 25.
Main boom extension	Side-folding 1 or 2-part jib, 23.3 ft or 42.7 ft. 0° and 30° offset.
Heavy-lift attachment	1 additional sheave on boom head.
Heavy-lift runner	3.9 ft long, 3-sheaves with several offset positions for working inside buildings.
Cabin	Air-suspended and heated driver's seat, heated and electrically adjustable outside mirrors, sliding rear window.
Searcher hook	
Cool box	

NOTES TO LIFTING CAPACITY

Ratings are in compliance with ISO 4305 and DIN 15019.2 (test load = 1.25 x suspended load + 0.1 x dead weight of boom head).
Weight of hook blocks and slings is part of the load, and is to be deducted from the capacity ratings.

Crane operation with main boom is permissible up to a

wind pressure of: 1.25 lb/ft²

wind speed of: 32 ft/s

Consult operation manual for further details.

Note: Data published herein is intended as a guide only and shall not be construed to warrant applicability for lifting purposes.
Crane operation is subject to the computer charts and operation manual both supplied with the crane.

KEY



Lifting capacities on outriggers 360°



Free on wheels

„D“

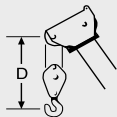

The information contained in this brochure merely consists of general descriptions and a broad compilation of performance features which might not apply precisely as described under specific application conditions or which may change as a result of further product development. The desired performance features only become binding once expressly agreed in the final contract.

Note: Data published herein is intended as a guide only and shall not be construed to warrant applicability for lifting purposes. Crane operation is subject to the computer charts and operation manual both supplied with the crane.

Subject to change without notice.

07 / 05

Terex Cranes Wilmington Operations

Mobile hydraulic and lattice-boom cranes
202 Raleigh St. · Wilmington, NC 28412 USA
Phone +1 910 395 8500 · Fax +1 910 395 8538
Email: american@american-crane.com