

TEREX | DEMAG

AC 50-1

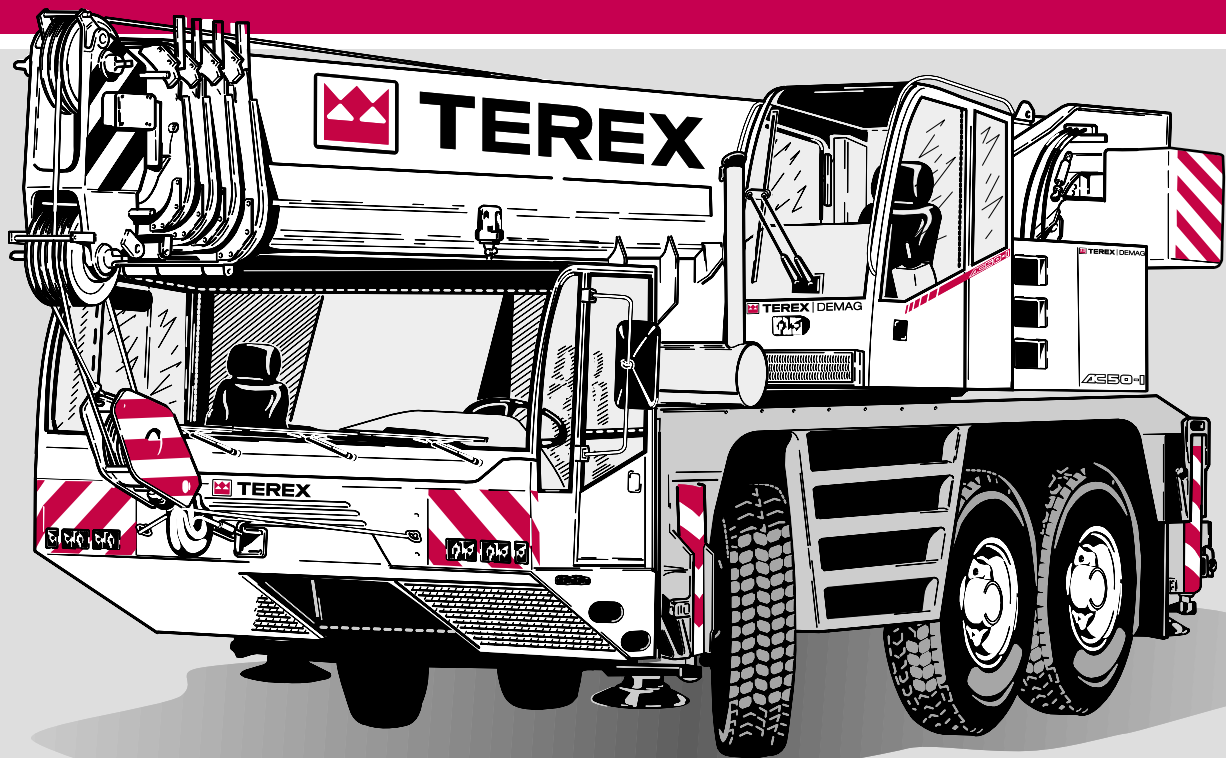

60t

HIGHLIGHTS

AC 50-1

- ▶ 131.2 ft main boom gives exceptional lifting capacity
- ▶ Roadable with 16,500 lb counterweight + 30.2 ft main boom extension, giving just 26,500 lb axle load
- ▶ Fully hydraulic boom system provides shortest telescoping times and enormous load telescoping capacity
- ▶ ABS, cruise control and automated transmission are standard features
- ▶ State-of-the-art super-soundproofed DaimlerChrysler engine technology type OM 926 LA
- ▶ 8.4 ft overall width with 14" and 16" tires

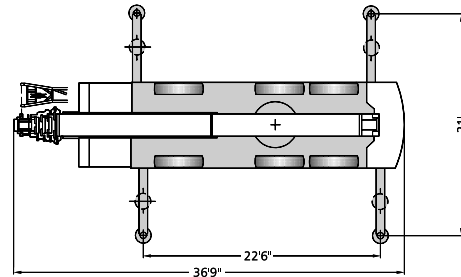
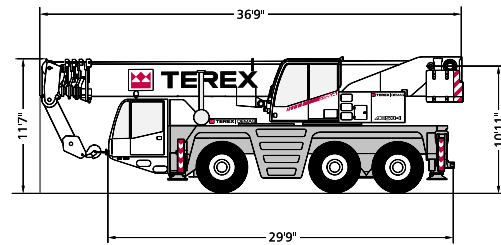
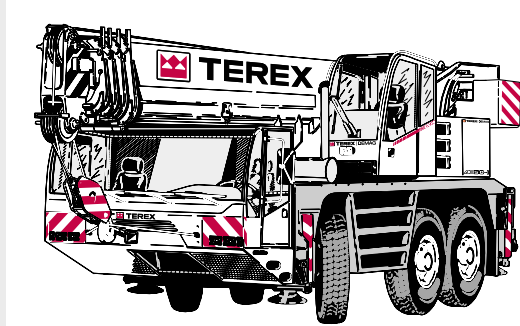

WWW. terex-cranes.com

Contents

Specifications

Dimensions	4
Specifications	7

1

Main boom

Working ranges	8
Lifting capacities	9

2

Main boom extension

Working ranges	10
Lifting capacities	11

3

Technical description

Carrier · Superstructure · Optional equipment	12
---	----

4

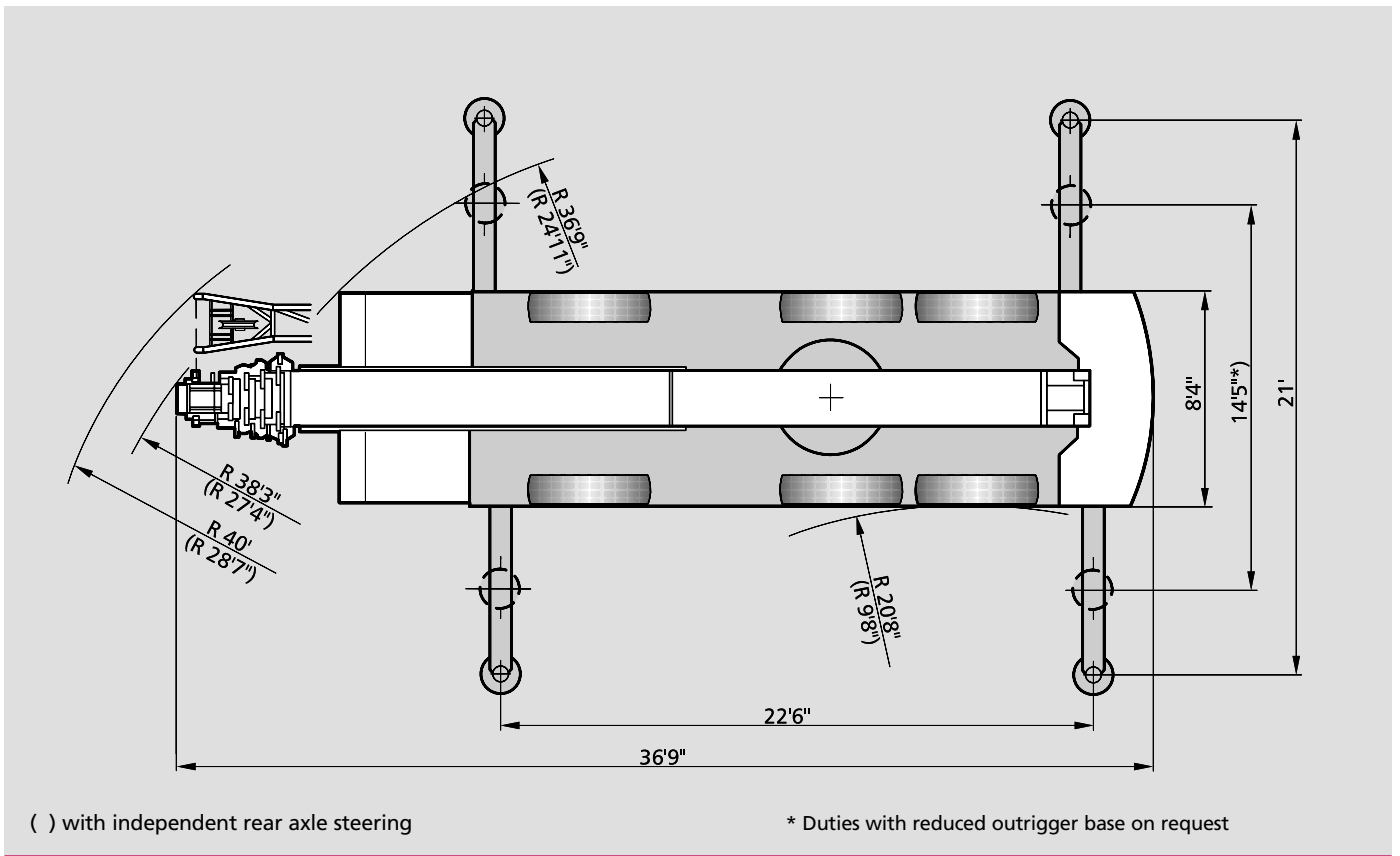
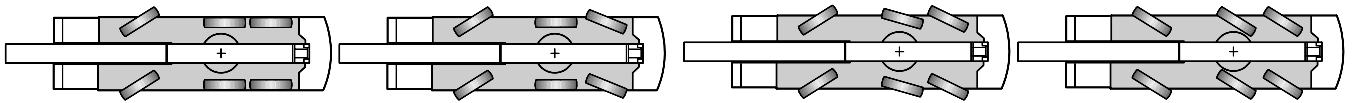

Notes to lifting capacity

Ratings are in compliance with ISO 4305 and DIN 15019.2 (test load = 1.25 x suspended load + 0.1 x dead weight of boom head).
Weight of hook blocks and slings is part of the load, and is to be deducted from the capacity ratings.

Crane operation with main boom is permissible up to a
wind pressure of 1.25 lb/ft²
wind speed of 32 ft

Consult operation manual for further details.

Note: Data published herein is intended as a guide only and shall not be construed to warrant applicability for lifting purposes.
Crane operation is subject to the computer charts and operation manual both supplied with the crane.

Specifications

1

Axle loads

Crane with main boom, 30.2 ft main boom extension, 16,500 lb counterweight, tires 14.00 R 25, single line hook	
Axles	3 x 26,500 lb
Total	79,500 lb

Working speeds (infinitely variable)

Mechanisms	Normal speed	High speed	Max. permissible line pull ¹⁾	Rope length
Hoist I	196.9 ft / min	410 ft / min	9,500 lb	591 ft
Hoist II	196.9 ft / min	410 ft / min	9,500 lb	591 ft
Slewing				max. 0 – 1.7 1/min
Telescoping speed				33.1 – 131.2 ft: 95 s
Boom elevation				-1,5° – +81,5°: 45 s

Carrier performance

Travel speed:	
Forward	0 . . 50 mph
Reverse	0 . . 7.5 mph
Gradeability in travel order	max. 45 %
Ground clearance	1' 1"

Hook block / Single line hook

Type	Possible load ¹⁾	Number of sheaves	Weight	„D“	max. reeving	Heavy-lift attachment
63	110,000 lb	6	1,058 lb	6.6 ft	12	2 add. sheaves
32	66,400 lb	3	815 lb	5.9 ft	7	
16	28,400 lb	1	551 lb	5.9 ft	3	
5	9,500 lb	Single line hook	287 lb	2.6 ft	1	

Remarks

¹⁾ varies depending on national regulations

Working ranges main boom

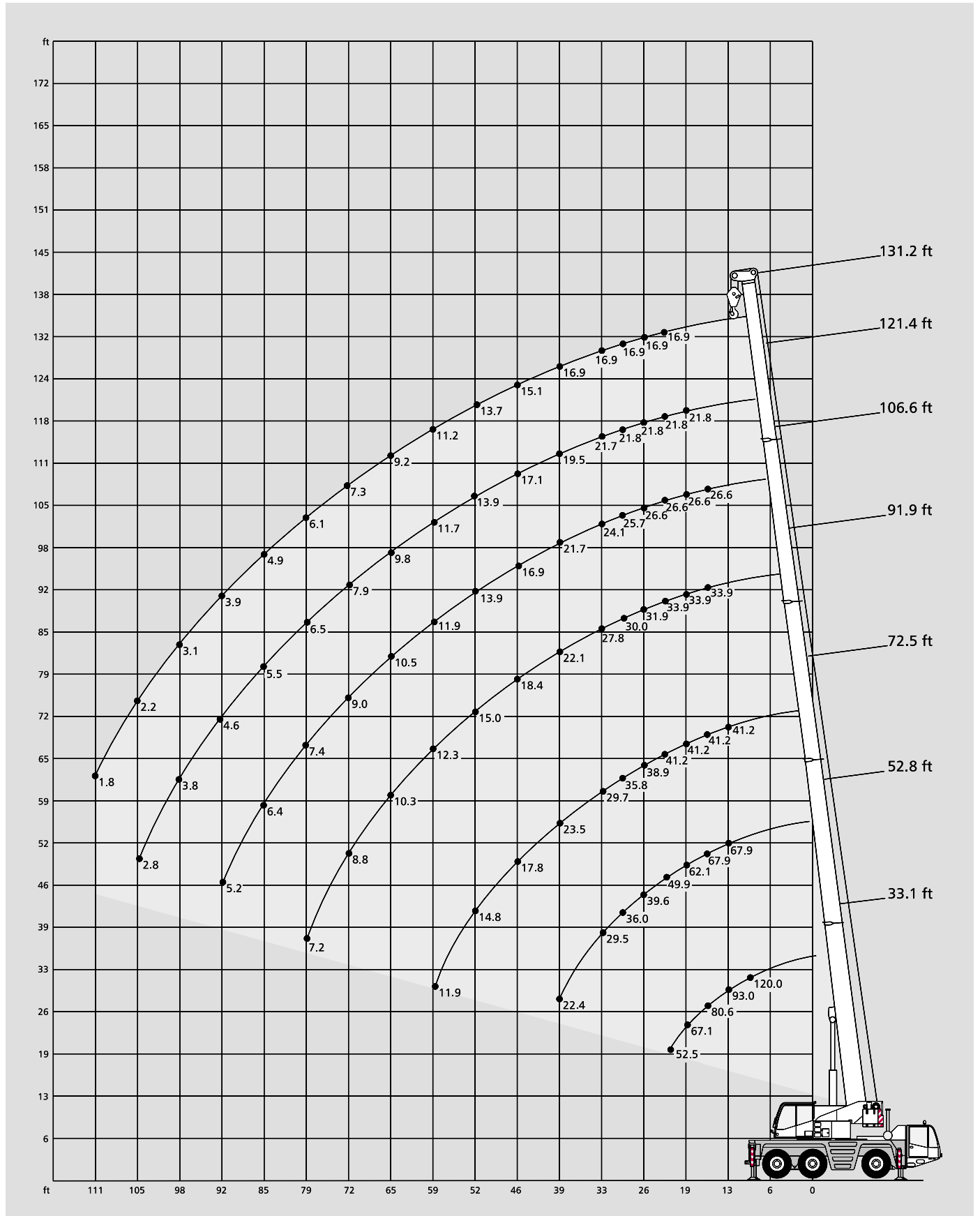

Lifting capacities main boom

20,900 lb



22.6 x 21.0 ft 360°



85%

Radius ft	Main boom								1)		Radius ft
	ft	33.1	52.8	72.5	91.9	106.6	121.4	131.2	33.1	52.8	
					1,000 lb						
10	120.0*	-	-	-	-	-	-	-	-	-	10
10	109.9	-	-	-	-	-	-	-	33.6	-	10
11	103.6	67.9	-	-	-	-	-	-	31.6	32.8	11
13	93.0	67.9	41.2	-	-	-	-	-	27.9	29.3	13
15	84.4	67.9	41.2	33.9	-	-	-	-	25.0	26.3	15
16	80.6	67.9	41.2	33.9	26.6	-	-	-	23.5	25.0	16
19	67.1	62.1	41.2	33.9	26.6	21.8	-	-	18.5	20.1	19
23	52.5	49.9	41.2	33.9	26.6	21.8	16.9	-	13.6	14.9	23
26	-	39.6	38.9	31.9	26.6	21.8	16.9	-	-	12.3	26
29	-	36.0	35.8	30.0	25.7	21.8	16.9	-	-	10.4	29
33	-	29.5	29.7	27.8	24.1	21.7	16.9	-	-	8.3	33
39	-	22.4	23.5	22.1	21.7	19.5	16.9	-	-	6.2	39
46	-	-	17.8	18.4	16.9	17.1	15.1	-	-	-	46
52	-	-	14.8	15.0	13.9	13.9	13.7	-	-	-	52
59	-	-	11.9	12.3	11.9	11.7	11.2	-	-	-	59
65	-	-	-	10.3	10.5	9.8	9.2	-	-	-	65
72	-	-	-	8.8	9.0	7.9	7.3	-	-	-	72
79	-	-	-	7.2	7.4	6.5	6.1	-	-	-	79
85	-	-	-	-	6.4	5.5	4.9	-	-	-	85
92	-	-	-	-	5.2	4.6	3.9	-	-	-	92
98	-	-	-	-	-	3.8	3.1	-	-	-	98
105	-	-	-	-	-	2.8	2.2	-	-	-	105
111	-	-	-	-	-	-	1.8	-	-	-	111

16,500 lb



22.6 x 21.0 ft 360°



85%

Radius ft	Main boom								1)		Radius ft
	ft	33.1	52.8	72.5	91.9	106.6	121.4	131.2	33.1	52.8	
					1,000 lb						
10	120.0*	-	-	-	-	-	-	-	-	-	10
10	109.9	-	-	-	-	-	-	-	33.6	-	10
11	103.5	67.9	-	-	-	-	-	-	31.6	32.8	11
13	93.0	67.9	41.2	-	-	-	-	-	27.9	29.3	13
15	83.8	67.9	41.2	33.9	-	-	-	-	23.3	25.2	15
16	78.7	67.9	41.2	33.9	26.6	-	-	-	21.1	22.9	16
19	65.0	61.7	41.2	33.9	26.6	21.8	-	-	16.2	17.8	19
23	47.4	45.0	41.2	33.9	26.6	21.8	16.9	-	11.8	13.2	23
26	-	35.6	38.9	31.9	26.6	21.8	16.9	-	-	10.7	26
29	-	33.2	32.8	30.0	25.7	21.8	16.9	-	-	9.1	29
33	-	26.6	27.7	26.4	24.1	21.7	16.9	-	-	7.2	33
39	-	20.2	21.3	21.3	20.0	19.5	16.9	-	-	5.1	39
46	-	-	16.0	16.5	15.1	15.1	15.1	-	-	-	46
52	-	-	13.0	13.6	13.5	12.7	11.9	-	-	-	52
59	-	-	10.3	11.0	11.0	10.1	9.2	-	-	-	59
65	-	-	-	9.2	9.2	8.3	7.4	-	-	-	65
72	-	-	-	7.5	7.5	6.8	5.7	-	-	-	72
79	-	-	-	6.3	6.3	5.2	4.5	-	-	-	79
85	-	-	-	-	5.3	4.4	3.7	-	-	-	85
92	-	-	-	-	4.3	3.2	2.8	-	-	-	92
98	-	-	-	-	-	2.6	2.0	-	-	-	98
105	-	-	-	-	-	1.9	-	-	-	-	105
111	-	-	-	-	-	-	-	-	-	-	111

Remarks



- * over rear
- 1) free on wheels, 0° over rear

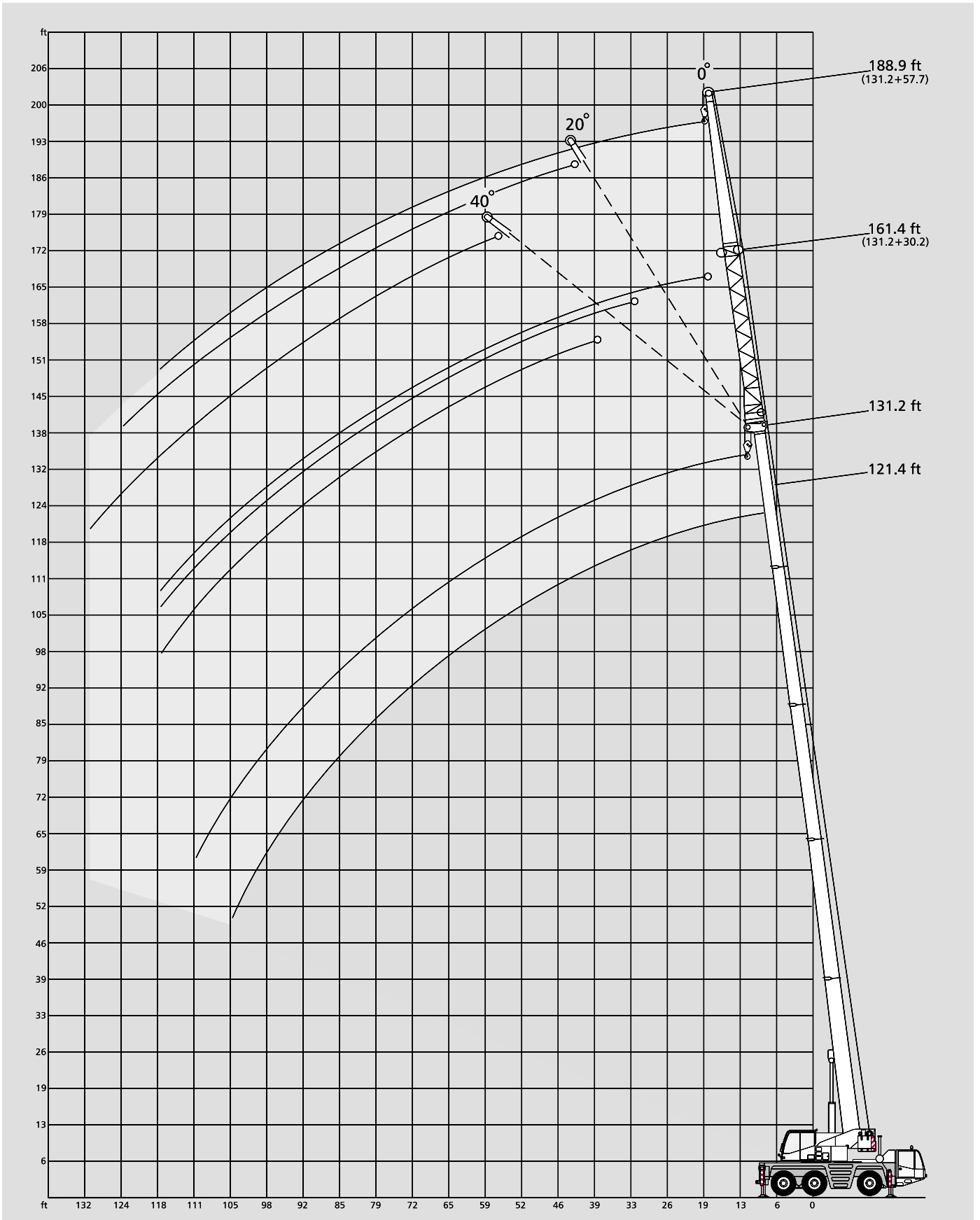

Working ranges main boom extension



Lifting capacities main boom extension

20,900 lb  22.6 x 21.0 ft 360° 85% 16,500 lb  22.6 x 21.0 ft 360° 85%

121.4 ft Main boom												
Radius	Extension											
	30.2 ft			57.7 ft								
	0°	20°	40°	0°*	0°	20°	40°	0°	20°	40°		
ft	1,000 lb			1,000 lb								
26	9.9	-	-	-	-	-	-	-	-	-		
29	9.9	-	-	-	-	-	-	-	-	-		
33	9.9	-	-	-	4.4	-	-	-	-	-		
39	9.9	9.0	-	-	4.4	-	-	-	-	-		
46	9.6	8.5	7.7	-	4.4	-	-	-	-	-		
52	9.4	8.1	7.5	-	4.4	4.4	-	-	-	-		
59	9.0	7.7	7.2	-	4.4	4.1	-	-	-	-		
65	8.6	7.5	7.0	-	4.4	3.9	-	-	-	-		
72	7.5	7.0	6.8	-	4.1	3.9	3.7	-	-	-		
79	6.3	6.7	6.8	-	4.1	3.7	3.7	-	-	-		
85	5.1	5.7	6.2	-	3.9	3.7	3.3	-	-	-		
92	4.1	4.6	5.0	-	3.7	3.3	3.3	-	-	-		
98	3.3	4.0	4.2	-	3.7	3.3	3.1	-	-	-		
105	2.6	2.8	3.0	-	2.8	3.0	3.0	-	-	-		
111	2.0	2.4	2.4	-	2.4	3.0	2.8	-	-	-		
118	1.5	1.7	-	-	1.9	2.4	2.8	-	-	-		
124	-	-	-	-	-	2.0	2.4	-	-	-		
131	-	-	-	-	-	1.5	1.7	-	-	-		
138	-	-	-	-	-	-	-	-	-	-		

121.4 ft Main boom												
Radius	Extension											
	30.2 ft			57.7 ft								
	0°	20°	40°	0°*	0°	20°	40°	0°	20°	40°		
ft	1,000 lb			1,000 lb								
26	9.9	-	-	-	-	-	-	-	-	-		
29	9.9	-	-	-	-	-	-	-	-	-		
33	9.9	-	-	-	4.4	-	-	-	-	-		
39	9.9	9.0	-	-	4.4	-	-	-	-	-		
46	9.6	8.5	7.7	-	4.4	-	-	-	-	-		
52	9.4	8.1	7.5	-	4.4	4.4	-	-	-	-		
59	9.0	7.7	7.2	-	4.4	4.1	-	-	-	-		
65	8.0	7.5	7.0	-	4.4	3.9	-	-	-	-		
72	6.6	7.0	6.8	-	4.1	3.9	3.7	-	-	-		
79	5.0	5.6	6.5	-	4.1	3.7	3.7	-	-	-		
85	4.2	4.8	5.1	-	3.9	3.7	3.3	-	-	-		
92	3.0	3.9	4.1	-	3.7	3.3	3.3	-	-	-		
98	2.4	2.9	3.3	-	2.9	3.3	3.1	-	-	-		
105	1.9	2.2	2.4	-	2.2	3.0	3.0	-	-	-		
111	-	1.5	2.0	-	1.8	2.4	2.8	-	-	-		
118	-	-	-	-	-	1.9	2.4	-	-	-		
124	-	-	-	-	-	1.5	1.8	-	-	-		
131	-	-	-	-	-	-	-	-	-	-		
138	-	-	-	-	-	-	-	-	-	-		

131.2 ft Main boom												
Radius	Extension											
	30.2 ft			57.7 ft								
	0°	20°	40°	0°*	0°	20°	40°	0°	20°	40°		
ft	1,000 lb			1,000 lb								
29	7.4	-	-	-	-	-	-	-	-	-		
33	7.4	-	-	3.5*	2.6	-	-	-	-	-		
39	7.4	7.4	-	3.5*	2.6	-	-	-	-	-		
46	7.4	7.4	-	3.5*	2.6	-	-	-	-	-		
52	7.4	7.2	7.0	3.5*	2.6	2.6	-	-	-	-		
59	7.4	7.0	6.8	3.5*	2.6	2.6	-	-	-	-		
65	7.4	6.6	6.4	3.5*	2.6	2.6	-	-	-	-		
72	7.2	6.3	6.1	3.5*	2.6	2.6	2.6	-	-	-		
79	6.1	6.1	5.7	3.5*	2.6	2.6	2.6	-	-	-		
85	5.1	5.5	5.5	3.5*	2.6	2.6	2.6	-	-	-		
92	4.1	4.6	5.0	3.5*	2.6	2.6	2.6	-	-	-		
98	3.1	3.8	4.2	3.3*	2.6	2.6	2.6	-	-	-		
105	2.4	2.8	3.0	2.6*	2.6	2.6	2.6	-	-	-		
111	1.8	2.2	2.4	2.2*	2.2	2.6	2.6	-	-	-		
118	-	1.5	1.9	1.7*	1.7	2.4	2.6	-	-	-		
124	-	-	-	-	-	2.0	2.4	-	-	-		
131	-	-	-	-	-	1.5	1.7	-	-	-		

131.2 ft Main boom												
Radius	Extension											
	30.2 ft			57.7 ft								
	0°	20°	40°	0°*	0°	20°	40°	0°	20°	40°		
ft	1,000 lb			1,000 lb								
29	7.4	-	-	-	-	-	-	-	-	-		
33	7.4	-	-	3.5*	2.6	-	-	-	-	-		
39	7.4	7.4	-	3.5*	2.6	-	-	-	-	-		
46	7.4	7.4	-	3.5*	2.6	-	-	-	-	-		
52	7.4	7.2	7.0	3.5*	2.6	2.6	-	-	-	-		
59	7.4	7.0	6.8	3.5*	2.6	2.6	-	-	-	-		
65	7.4	6.6	6.4	3.5*	2.6	2.6	-	-	-	-		
72	6.4	6.3	6.1	3.5*	2.6	2.6	2.6	-	-	-		
79	5.0	5.6	5.7	3.5*	2.6	2.6	2.6	-	-	-		
85	4.2	4.6	5.1	3.5*	2.6	2.6	2.6	-	-	-		
92	3.0	3.7	4.1	3.2*	2.6	2.6	2.6	-	-	-		
98	2.4	2.9	3.1	2.6*	2.6	2.6	2.6	-	-	-		
105	1.7	2.2	2.4	1.9*	2.2	2.6	2.6	-	-	-		
111	-	1.8	1.8	1.5*	1.5	2.4	2.6	-	-	-		
118	-	-	-	-	-	1.7	2.4	-	-	-		
124	-	-	-	-	-	-	1.8	-	-	-		
131	-	-	-	-	-	-	-	-	-	-		

Remarks

* Special length: main boom 126.0 ft



Technical description

Carrier

Drive / steering	6 x 4 x 2.
Frame	Monobox main frame with outrigger boxes integral, of high-strength fine-grain structural steel.
Outriggers	Four hydraulically telescoping outrigger beams with hydraulic jack legs.
Engine	DaimlerChrysler OM 926 LA, water-cooled 6-cylinder engine, output to DIN: 240 kW (326 hp), max. torque 1300 Nm at 1200-1500 ¹ /min. Fuel tank capacity: 87 gallons.
Transmission	Automated powershift transmission with torque-converter and integral transfer case, 6 speeds forward and 2 reverse, longitudinal differential lockout control.
Axles	Axle 1: with planetary hubs, steer, transverse differential lockout control; axle 2: non-drive, non-steer; axle 3: with planetary hubs, non-steer, transverse differential lockout control.
Suspension	Hydropneumatic suspension, all axles hydraulically blockable.
Wheels and tires	6 disk-type wheels fitted with 14.00 R 25 tires. Single wheels on all axles.
Steering	Dual-circuit hydraulic steering.
Brakes	Service brake: dual-line air system, acting on all wheels, ABS. Parking brake: spring-loaded type on axles 2 and 3. Sustained action brake: exhaust brake, constant choke valve, automatic downhill brake control.
Electrical equipment	24 V system.
2-man driver's cab	Rubber-mounted all steel driver's cab with safety glazing, controls and instrumentation, air-sprung and heated driver's and passenger seat, vertically adjustable steering wheel, electrically adjustable and heated outside mirrors, rotaflare warning light, cruise control, air-conditioning as standard.

Superstructure

Main boom	Boom base and 4 telescopic sections, fabricated from fine-grain structural steel, telescoping with partial load, anti-deflection Demag ovaloid design.
Counterweight	16,500 lb fixed on superstructure.
Hydraulic system	Powered by carrier engine, 1 variable-displacement axial piston pump and separate fixed-displacement pump to allow 3 simultaneous, independent working movements.
Hoist	Fixed-displacement axial-piston motor, hoist drum with planetary reduction integral and spring-loaded multi-disk brake.
Slew unit	Hydraulic motor with planetary reduction, foot-pedal operated brake and spring-loaded holding brake.
Boom elevation	1 differential cylinder with automatically controlled lowering brake valve.
Crane cab	Spacious all-steel comfortable cab with sliding door and large hinged windscreen, tiltable 20°, roof window with armoured glass, full instrumentation and crane controls, working light. Self-contained hot water heater with timer, thermostat-controlled. Windscreen washer and intermittent control type windscreen wiper, air-conditioning as standard.
Safety devices	Electronic safe load indicator with digital readout for hook load, rated load, boom length, boom angle, load radius. Integrated display to indicate the percentage of tele sequence, limit switches on hoist and lowering motions, pressure-relief and safety holding valves.
Hydraulic servo control	Hydraulic pilot-control by self-centering control levers.

Optional equipment

Drive / steering	6 x 6 x 6 + top-steer facility.
Wheels and tires	16.00 R 25, 20.5 R 25 (Note increased weight and width!)
Trailer coupling	For central axle trailers with max. 53,000 lb total weight and ABS air hookup: D = 190; D _C = 155; V = 75.
Hoist II	Fixed-displacement axial piston motor, hoist drum with planetary reduction integral and spring-loaded multi-disk brake (avoids re-reeving of hoist line when using the optional jib). Installed with assist crane.
Main boom extension	Side-folding 1 or 2-part jib, 30.2 ft or 57.7 ft. 0°, 20° and 40° offset.
Additional counterweight	4,400 lb.
Heavy-lift attachment	2 additional sheaves on boom head for duties over 75,800 lb.
Heavy-lift runner	3.9 ft long, 1-sheave.
Handling facility for additional counterweight	
Telma electric retarder	
Rooster sheave	1-sheave.

Key



Counterweight



Lifting capacities on outriggers 360°



free on wheels, 0° over rear

„D“

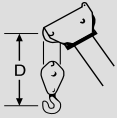

The information contained in this brochure merely consists of general descriptions and a broad compilation of performance features which might not apply precisely as described under specific application conditions or which may change as a result of further product development.
The desired performance features only become binding once expressly agreed in the final contract.

Subject to change without notice. · Machine operation is subject to computer charts only.

08 / 04

Terex Cranes Wilmington Operations

Mobile hydraulic and lattice-boom cranes
202 Raleigh St.
Wilmington, NC 28412 USA
Phone +1 910 395 8500
Fax +1 910 395 8538
Email american@american-crane.com

Order Nr. AC 50-1 USA B2 – 201 024 12

www.terex-cranes.com