



CHALLENGER 3180

**65 USt capacity
All Terrain Crane
Datasheet
imperial**

CHALLENGER 3180



WORKS FOR YOU.™

	Page:
Dimensions	4
Counterweight	5
Specifications	6
Equipment	7

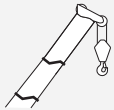

HA

Main boom	8
-----------------	---



HAV



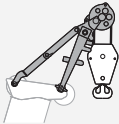











Folding swing-away jib	16
------------------------------	----

















MSF2

Runner	20
--------------	----

Technical description	24
-----------------------------	----

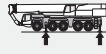
-  Counterweight
-  Lifting capacities on outriggers · 360°
-  Radius
-  Main boom
-  Folding swing-away jib
-  Runner
-  Max. axle loads
-  Mechanism
-  Tires
-  Hook block
-  Hoist
-  Travel speed
-  Gradeability – road
-  Gradeability – off road
-  Engine

-  Slewing
-  Boom telescoping
-  Boom elevation
-  Workings speeds
-  Max. line pull
-  Rope diameter
-  Rope length
-  Hook block (capacity-sheaves-rope diameter)
-  Number of lines
-  Possible load of hook block
-  Weight of hook block
-  Distance head sheave axle – hook ground
-  Number of sheaves in boom head
-  Supporting force
-  Length of stroke (support cylinders)
-  Payload incl. rear storage box

COUNTERWEIGHT

CHALLENGER 3180

Parts

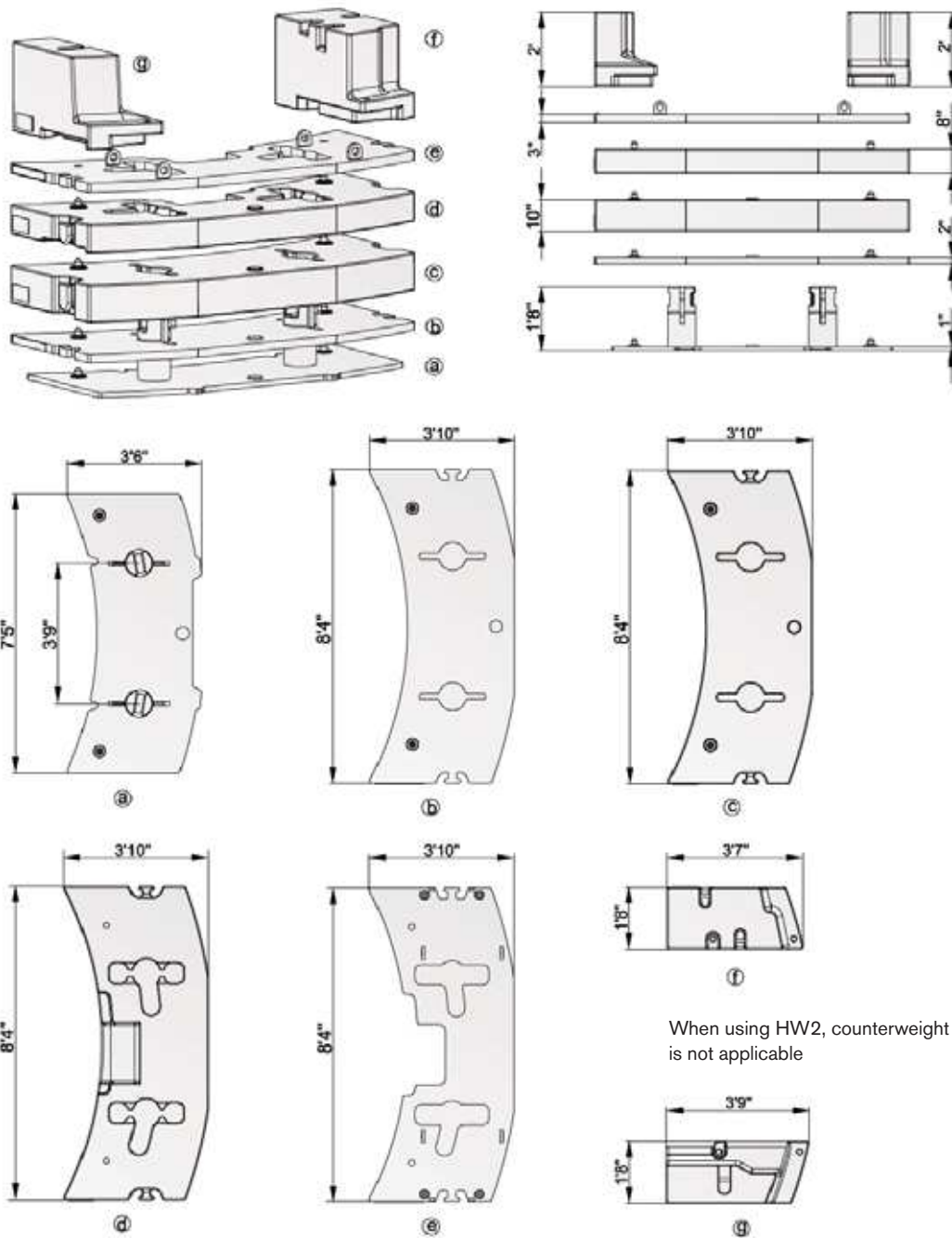









When using HW2, counterweight „g“ is not applicable







Configurations

	Ⓐ 1,300 lb	Ⓑ 2,000 lb	Ⓒ 8,400 lb	Ⓓ 6,000 lb	Ⓔ 2,000 lb	Ⓕ 4,200 lb	Ⓖ 2,900 lb
7,100 lb						X	X
8,400 lb	X					X	X
9,000 lb					X	X	X
10,400 lb	X	X				X	X
12,400 lb	X	X			X	X	X
15,000 lb				X	X	X	X
16,300 lb	X			X	X	X	X
18,700 lb	X		X		X	X	X
20,700 lb	X	X	X		X	X	X
26,700 lb	X	X	X	X	X	X	X



SPECIFICATIONS

CHALLENGER 3180



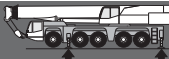

								
	Total							
26,500 lb	79,400 lb	6 x 4 x 6	240 kW	385/95R25	50-3-18	10,400 lb	-	1,760 lb
26,500 lb	79,400 lb	6 x 4 x 6	265 kW	385/95R25	50-3B-18	7,100 lb	52.5 ft	1,320 lb
26,500 lb	79,400 lb	6 x 6 x 6	240 kW	445/95R25	50-3B-18	8,400 lb	52.5 ft	880 lb
26,500 lb	79,400 lb	6 x 6 x 6	265 kW	445/95R25	8-0-18	7,100 lb	52.5 ft	880 lb
28,700 lb	86,000 lb	6 x 6 x 6	265 kW	445/95R25	50-3B-18	12,400 lb	52.5 ft	1,100 lb
30,200 lb	90,400 lb	6 x 6 x 6	265 kW	445/95R25	8-0-18	18,700 lb	-	1,760 lb
34,200 lb	101,400 lb	6 x 6 x 6	265 kW	445/95R25	50-3-18	26,700 lb	52.5 ft	1,760 lb





	1 Highway > 27.8 mph		4* Off-wall
	2 City < 27.8 mph		5* Crab steer mode
	3* Minimum turning radius < 3.1 mph		6* All wheel steering







* must be activated







		
70,600 lb	88,200 lb	52.8 mph ¹⁾
2'-4"	2'-4"	

¹⁾ Depending on tire type, size and country specific legislation

 265 kW			
	385/95R25 14.00R25	445/95R25 16.00R25	525/80R25 20.50R25
	55 %	50 %	50 %
	> 80 %	> 80 %	> 80 %

 240 kW			
	385/95R25 14.00R25	445/95R25 16.00R25	525/80R25 20.50R25
	40 %	35 %	35 %
	75 %	70 %	70 %

					
1	15,000	8-0-18	3	374 lb	3.3 ft
2	29,600	20-1-18	3	662 lb	5.9 ft
3	44,100	20-1-18	3	662 lb	5.9 ft
4	58,700	50-3-18	3	1,210 lb	5.9 ft
5	73,000	50-3-18	3	1,210 lb	5.9 ft
6	87,100	50-3-18	3	1,210 lb	5.9 ft

			
1	394 ft ³ /min (265 kW) 348 ft ³ /min (240 kW)	15,040 lb	0.7" 787 ft
2	394 ft ³ /min (265 kW) 348 ft ³ /min (240 kW)	15,040 lb	0.7" 787 ft
	1,8 rpm		
	ca. 490 s (34.1-164.0 ft)		
	ca. 50 s (-5° - 82°)		

EQUIPMENT

CHALLENGER 3180

HAV16

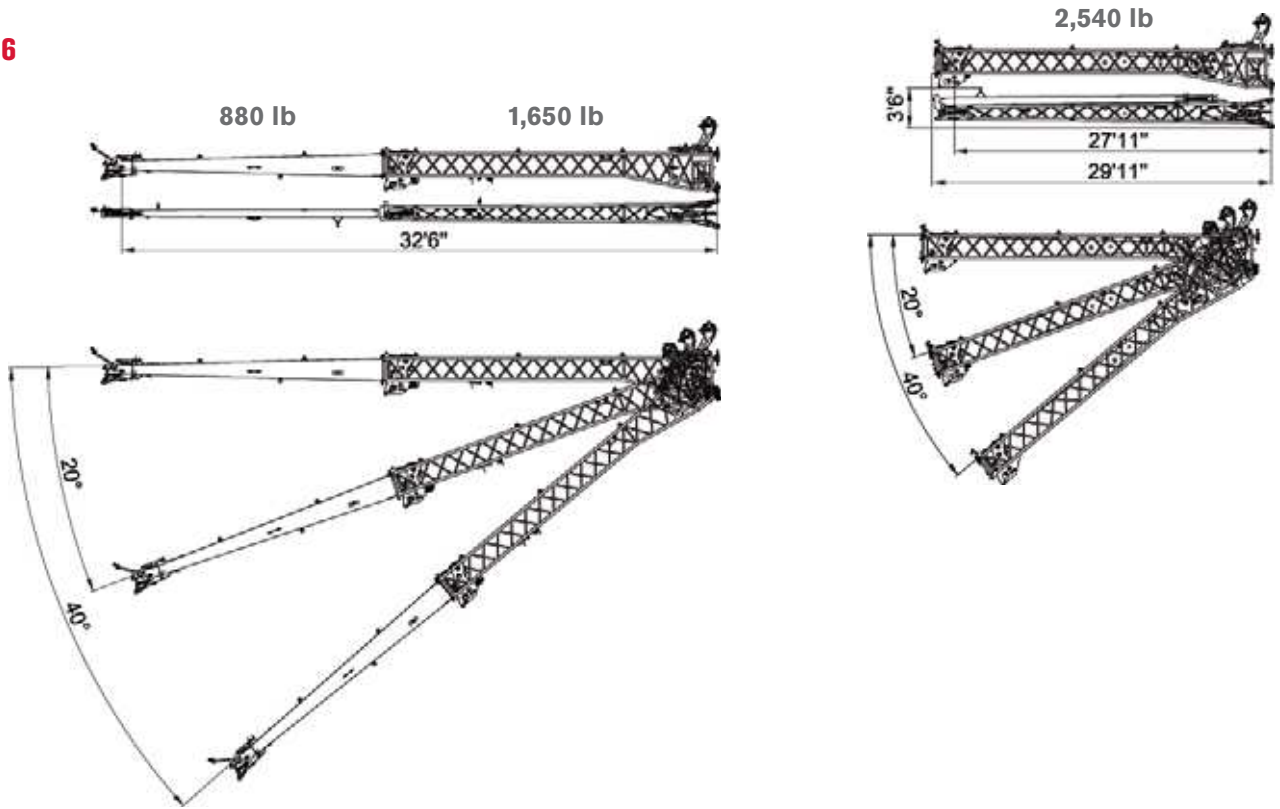

MSF2

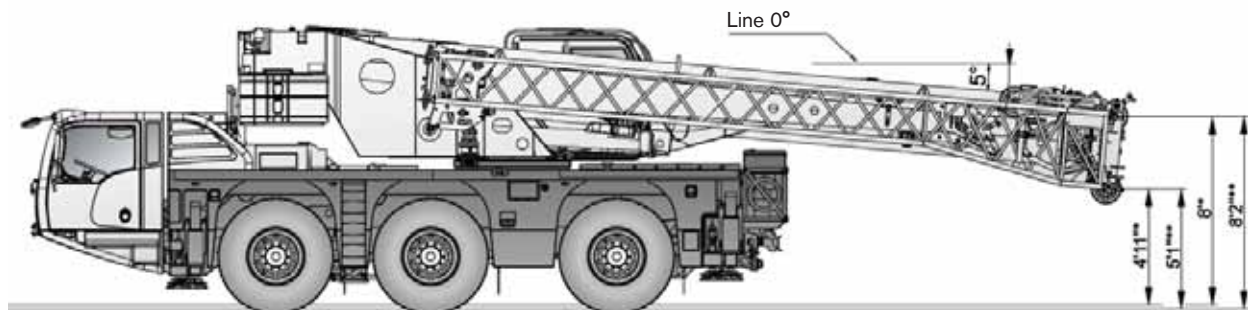
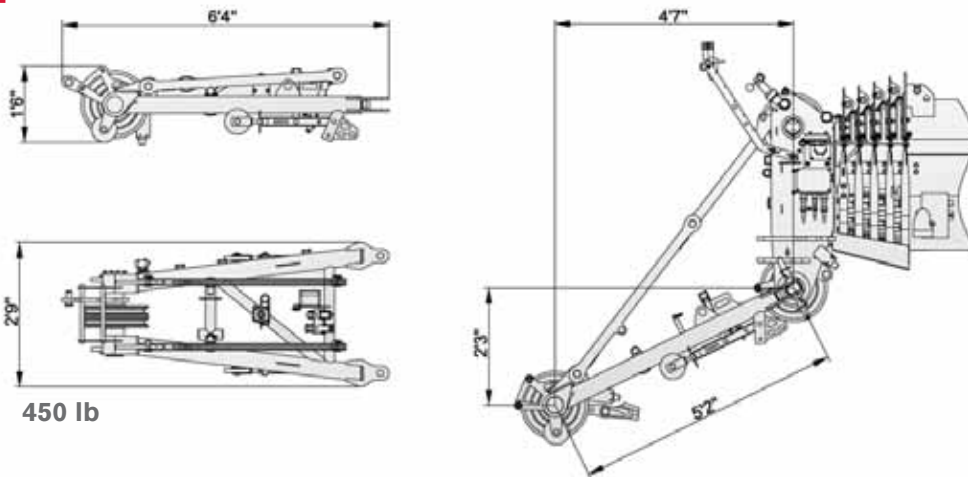

* 385/95R25

** 445/95R25

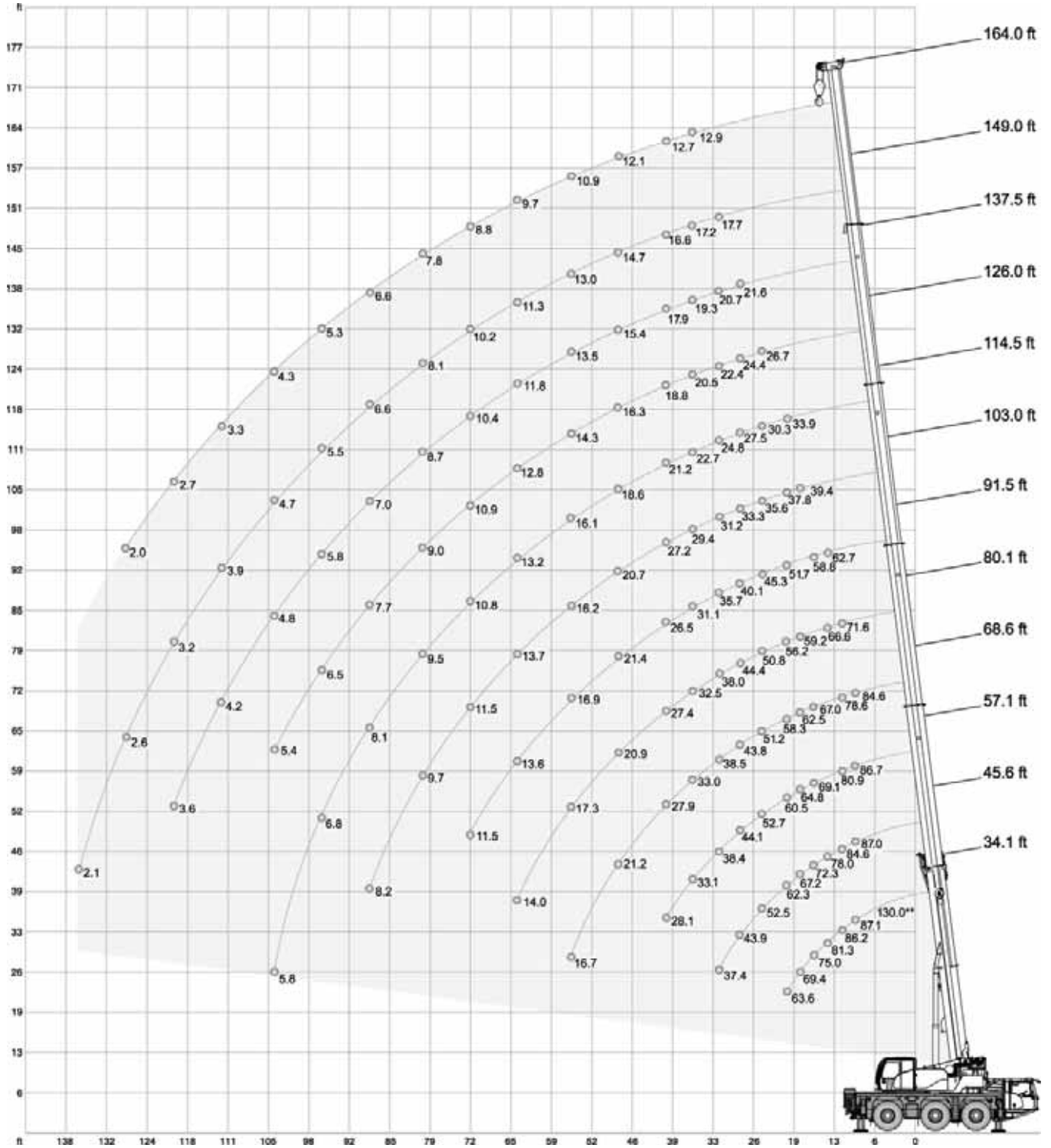
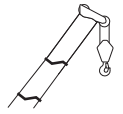

26,700 lb		22.6 x 21.3 ft		360°		265 kW*		85 %							
0°															
34.1 ft		34.1 ft	45.6 ft	57.1 ft	68.6 ft	80.1 ft	91.5 ft	103.0 ft	114.5 ft	126.0 ft	137.5 ft	149.0 ft	164.0 ft		
ft		1,000 lb												ft	
	130,0**	-	-	-	-	-	-	-	-	-	-	-	-	-	-
10	87,1	87,1	87,0	86,7	84,6	-	-	-	-	-	-	-	-	-	10
12	86,2	86,0	84,6	80,9	78,6	71,6	-	-	-	-	-	-	-	-	12
14	81,3	80,0	78,0	74,2	72,6	66,6	62,7	-	-	-	-	-	-	-	14
16	75,0	72,8	72,3	69,1	67,0	62,2	58,8	-	-	-	-	-	-	-	16
18	69,4	66,8	67,2	64,8	62,5	59,2	55,2	39,4	-	-	-	-	-	-	18
20	63,6	61,1	62,3	60,5	58,3	56,2	51,7	37,8	33,9	-	-	-	-	-	20
24	-	-	52,5	52,7	51,2	50,8	45,3	35,6	30,3	26,7	-	-	-	-	24
28	-	-	43,9	44,1	43,8	44,4	40,1	33,3	27,5	24,4	21,6	-	-	-	28
32	-	-	37,4	38,4	38,5	38,0	35,7	31,2	24,8	22,4	20,7	17,7	-	-	32
36	-	-	-	33,1	33,0	32,5	31,1	29,4	22,7	20,5	19,3	17,2	12,9	-	36
40	-	-	-	28,1	27,9	27,4	26,5	27,2	21,2	18,8	17,9	16,6	12,7	-	40
48	-	-	-	-	21,2	20,9	21,4	20,7	18,6	16,3	15,4	14,7	12,1	-	48
56	-	-	-	-	16,7	17,3	16,9	16,2	16,1	14,3	13,5	13,0	10,9	-	56
64	-	-	-	-	-	14,0	13,6	13,7	13,2	12,8	11,8	11,3	9,7	-	64
72	-	-	-	-	-	-	11,5	11,5	10,8	10,9	10,4	10,2	8,8	-	72
80	-	-	-	-	-	-	-	9,7	9,5	9,0	8,7	8,1	7,8	-	80
88	-	-	-	-	-	-	-	8,2	8,1	7,7	7,0	6,6	6,6	-	88
96	-	-	-	-	-	-	-	-	6,8	6,5	5,8	5,5	5,3	-	96
104	-	-	-	-	-	-	-	-	5,8	5,4	4,8	4,7	4,3	-	104
112	-	-	-	-	-	-	-	-	-	-	4,2	3,9	3,3	-	112
120	-	-	-	-	-	-	-	-	-	-	3,6	3,2	2,7	-	120
128	-	-	-	-	-	-	-	-	-	-	-	2,6	2,0	-	128
136	-	-	-	-	-	-	-	-	-	-	-	2,1	-	-	136
1)	31,3	31,3	22,9	17,6	14,3	11,5	9,5	7,5	5,5	4,0	3,1	1,8	0	1)	

* see page 23

** Capacity class



1) Capacities with horizontal boom



		18,700 lb		22.6 x 21.3 ft		360°		265 kW*		85 %																	
		34.1 ft		45.6 ft		57.1 ft		68.6 ft		80.1 ft		91.5 ft		103.0 ft		114.5 ft		126.0 ft		137.5 ft		149.0 ft		164.0 ft			
ft		1,000 lb																								ft	
10		87,1	87,0	86,7	84,6	-	-	-	-	-	-	-	-	-	-	-	-	-	-	-	-	-	-	-	-	10	
12		85,8	84,6	80,9	78,6	71,6	-	-	-	-	-	-	-	-	-	-	-	-	-	-	-	-	-	-	-	12	
14		79,5	78,0	74,2	72,6	66,6	62,7	-	-	-	-	-	-	-	-	-	-	-	-	-	-	-	-	-	-	14	
16		72,3	72,3	69,1	67,0	62,2	58,8	-	-	-	-	-	-	-	-	-	-	-	-	-	-	-	-	-	-	16	
18		65,8	66,6	64,8	62,5	59,2	55,2	39,4	-	-	-	-	-	-	-	-	-	-	-	-	-	-	-	-	-	18	
20		59,5	60,8	60,2	58,2	56,2	51,7	37,8	33,9	-	-	-	-	-	-	-	-	-	-	-	-	-	-	-	-	20	
24		-	49,7	49,9	49,4	49,8	45,1	35,6	30,3	26,7	-	-	-	-	-	-	-	-	-	-	-	-	-	-	-	24	
28		-	40,6	41,7	42,0	41,1	38,4	33,3	27,5	24,4	21,6	-	-	-	-	-	-	-	-	-	-	-	-	-	-	28	
32		-	33,4	34,1	34,1	33,5	32,2	31,2	24,8	22,4	20,7	17,7	-	-	-	-	-	-	-	-	-	-	-	-	-	32	
36		-	-	28,7	28,7	28,0	27,4	27,4	22,7	20,5	19,3	17,2	12,9	-	-	-	-	-	-	-	-	-	-	-	-	36	
40		-	-	24,0	24,0	24,0	24,2	23,3	21,2	18,8	17,9	16,6	12,7	40												40	
48		-	-	-	18,4	18,7	18,2	17,5	17,8	16,0	15,3	14,7	12,1	48												48	
56		-	-	-	14,9	14,7	14,4	14,5	13,7	13,7	13,0	12,6	10,9	56												56	
64		-	-	-	-	11,8	12,0	11,6	11,5	11,1	10,7	10,2	9,5	64												64	
72		-	-	-	-	-	10,0	9,7	9,5	9,1	8,4	8,0	7,5	72												72	
80		-	-	-	-	-	-	8,2	7,7	7,3	6,8	6,8	6,2	80												80	
88		-	-	-	-	-	-	6,8	6,4	6,0	5,8	5,5	4,9	88												88	
96		-	-	-	-	-	-	-	5,2	5,0	5,0	4,3	3,9	96												96	
104		-	-	-	-	-	-	-	4,3	3,9	4,1	3,4	2,8	104												104	
112		-	-	-	-	-	-	-	-	-	3,3	2,6	2,2	112												112	
120		-	-	-	-	-	-	-	-	-	2,5	2,1	-	120												120	
1)		31,3	22,9	17,6	13,2	10,1	7,7	6,0	4,2	2,6	2,0	0	0	1)												1)	

		12,300 lb		22.6 x 21.3 ft		360°		265 kW*		85 %																	
		34.1 ft		45.6 ft		57.1 ft		68.6 ft		80.1 ft		91.5 ft		103.0 ft		114.5 ft		126.0 ft		137.5 ft		149.0 ft		164.0 ft			
ft		1,000 lb																								ft	
10		87,1	87,0	86,7	84,6	-	-	-	-	-	-	-	-	-	-	-	-	-	-	-	-	-	-	-	-	10	
12		85,7	84,6	80,9	78,6	71,6	-	-	-	-	-	-	-	-	-	-	-	-	-	-	-	-	-	-	-	12	
14		79,1	78,0	74,2	72,6	66,6	62,7	-	-	-	-	-	-	-	-	-	-	-	-	-	-	-	-	-	-	14	
16		71,7	72,3	69,1	67,0	62,2	58,8	-	-	-	-	-	-	-	-	-	-	-	-	-	-	-	-	-	-	16	
18		64,4	65,5	64,2	62,4	59,2	55,2	39,4	-	-	-	-	-	-	-	-	-	-	-	-	-	-	-	-	-	18	
20		57,3	58,6	58,8	57,6	55,7	51,4	37,8	33,9	-	-	-	-	-	-	-	-	-	-	-	-	-	-	-	-	20	
24		-	46,5	47,0	46,6	44,2	41,1	35,6	30,3	26,7	-	-	-	-	-	-	-	-	-	-	-	-	-	-	-	24	
28		-	36,6	37,4	37,4	36,0	33,6	32,5	27,5	24,4	21,6	-	-	-	-	-	-	-	-	-	-	-	-	-	-	28	
32		-	29,1	30,0	29,8	29,3	29,6	27,9	24,6	22,4	20,7	17,7	-	-	-	-	-	-	-	-	-	-	-	-	-	32	
36		-	-	25,0	24,9	25,1	25,2	23,9	22,2	20,2	19,3	17,2	12,9	36												36	
40		-	-	20,7	21,6	21,6	20,9	20,3	20,3	18,2	17,7	16,6	12,7	40												40	
48		-	-	-	16,4	16,2	15,9	15,9	15,3	15,3	14,4	13,8	11,9	48												48	
56		-	-	-	12,8	12,8	12,8	12,5	12,4	11,9	11,5	10,5	9,8	56												56	
64		-	-	-	-	10,4	10,2	10,1	9,7	9,5	8,9	8,5	7,5	64												64	
72		-	-	-	-	-	8,4	8,2	7,8	7,3	7,3	6,9	5,8	72												72	
80		-	-	-	-	-	-	6,6	6,2	6,0	6,0	5,3	4,5	80												80	
88		-	-	-	-	-	-	5,4	5,0	4,7	4,7	4,2	3,4	88												88	
96		-	-	-	-	-	-	-	4,1	3,6	3,8	3,1	2,4	96												96	
104		-	-	-	-	-	-	-	3,2	2,7	3,0	2,3	1,6	104												104	
112		-	-	-	-	-	-	-	-	-	2,2	-	-	112												112	
1)		31,3	22,5	15,4	11,2	8,6	6,4	4,6	3,1	1,8	0	0	0	1)												1)	

* see page 23

1) Capacities with horizontal boom

		10,400 lb		22.6 x 21.3 ft		360°		265 kW*		85 %				
														
		34.1 ft	45.6 ft	57.1 ft	68.6 ft	80.1 ft	91.5 ft	103.0 ft	114.5 ft	126.0 ft	137.5 ft	149.0 ft	164.0 ft	
ft		1,000 lb											ft	
10		87,1	87,0	86,7	84,6	-	-	-	-	-	-	-	-	10
12		85,6	84,6	80,9	78,6	71,6	-	-	-	-	-	-	-	12
14		79,0	78,0	74,2	72,6	66,6	62,7	-	-	-	-	-	-	14
16		71,1	72,0	69,1	67,0	62,2	58,8	-	-	-	-	-	-	16
18		63,6	64,9	63,6	61,1	58,1	54,2	39,4	-	-	-	-	-	18
20		56,2	57,6	57,7	55,0	53,5	49,4	37,8	33,9	-	-	-	-	20
24		-	45,0	46,5	45,1	42,2	39,1	35,5	30,3	26,7	-	-	-	24
28		-	34,8	35,8	35,7	34,3	32,6	31,6	27,5	24,4	21,6	-	-	28
32		-	27,7	28,4	28,4	28,4	28,5	26,5	24,3	22,4	20,7	17,7	-	32
36		-	-	23,7	23,7	24,6	24,0	22,7	21,8	19,8	18,9	17,2	12,9	36
40		-	-	19,7	20,7	20,5	19,9	19,9	19,4	18,0	17,0	16,5	12,7	40
48		-	-	-	15,5	15,3	15,6	15,1	15,0	14,5	13,9	13,0	11,7	48
56		-	-	-	12,0	12,4	12,2	11,9	11,7	11,3	10,7	9,9	9,2	56
64		-	-	-	-	9,9	9,7	9,5	9,3	8,8	8,4	7,9	6,8	64
72		-	-	-	-	-	7,8	7,5	7,3	6,9	6,9	6,2	5,1	72
80		-	-	-	-	-	-	6,2	5,7	5,3	5,5	4,9	3,8	80
88		-	-	-	-	-	-	4,9	4,6	4,3	4,3	3,7	2,8	88
96		-	-	-	-	-	-	-	3,6	3,3	3,3	2,8	2,0	96
104		-	-	-	-	-	-	-	2,9	2,5	2,5	1,9	-	104
1)		31,3	21,4	14,8	10,6	8,2	6,0	4,2	2,6	1,5	0	0	0	1)

		8,400 lb		22.6 x 21.3 ft		360°		265 kW*		85 %				
														
		34.1 ft	45.6 ft	57.1 ft	68.6 ft	80.1 ft	91.5 ft	103.0 ft	114.5 ft	126.0 ft	137.5 ft	149.0 ft	164.0 ft	
ft		1,000 lb											ft	
10		87,1	87,0	86,7	84,6	-	-	-	-	-	-	-	-	10
12		85,5	84,6	80,9	78,6	71,6	-	-	-	-	-	-	-	12
14		78,8	78,0	74,2	72,6	66,6	62,7	-	-	-	-	-	-	14
16		70,5	71,5	69,1	67,0	62,2	58,8	-	-	-	-	-	-	16
18		62,8	64,1	63,2	59,9	56,9	53,2	39,4	-	-	-	-	-	18
20		55,2	56,6	56,7	52,6	51,1	47,2	37,8	33,9	-	-	-	-	20
24		-	42,8	44,6	43,0	40,4	37,3	35,0	30,3	26,7	-	-	-	24
28		-	33,2	34,0	34,0	32,8	31,8	30,2	26,8	24,4	21,6	-	-	28
32		-	26,3	27,0	27,0	27,4	27,2	25,2	24,0	21,8	20,7	17,7	-	32
36		-	-	22,6	22,7	23,4	22,9	21,5	21,2	19,4	18,4	17,0	12,9	36
40		-	-	19,2	19,6	19,4	19,0	19,2	18,3	17,9	16,9	16,0	12,7	40
48		-	-	-	14,7	14,8	14,8	14,5	14,2	14,0	13,0	12,1	11,3	48
56		-	-	-	11,4	11,6	11,4	11,3	10,9	10,7	9,8	9,5	8,4	56
64		-	-	-	-	9,3	9,0	9,0	8,6	8,2	8,0	7,3	6,2	64
72		-	-	-	-	-	7,3	7,1	6,7	6,4	6,4	5,5	4,4	72
80		-	-	-	-	-	-	5,7	5,3	4,9	4,9	4,2	3,4	80
88		-	-	-	-	-	-	4,5	4,1	3,8	3,8	3,2	2,4	88
96		-	-	-	-	-	-	-	3,2	2,9	2,9	2,2	-	96
104		-	-	-	-	-	-	-	2,5	2,1	2,1	-	-	104
1)		31,3	20,3	13,9	9,9	7,5	5,5	3,7	2,2	0	0	0	0	1)

* see page 23



1) Capacities with horizontal boom



7,100 lb		22.6 x 21.3 ft		360°		265 kW*		85 %					
ft	34.1 ft	45.6 ft	57.1 ft	68.6 ft	80.1 ft	91.5 ft	103.0 ft	114.5 ft	126.0 ft	137.5 ft	149.0 ft	164.0 ft	ft
1,000 lb													
10	87,1	87,0	86,7	84,6	-	-	-	-	-	-	-	-	10
12	85,5	84,6	80,9	78,6	71,6	-	-	-	-	-	-	-	12
14	78,8	78,0	74,2	72,6	66,6	62,7	-	-	-	-	-	-	14
16	70,0	71,0	69,1	67,0	62,2	58,8	-	-	-	-	-	-	16
18	62,1	63,4	62,3	59,2	56,2	52,4	39,4	-	-	-	-	-	18
20	54,5	55,9	54,9	52,5	49,6	45,7	37,8	33,9	-	-	-	-	20
24	-	42,2	43,4	41,7	39,1	36,2	34,7	30,2	26,7	-	-	-	24
28	-	32,2	33,1	33,1	31,7	31,4	29,2	26,4	24,3	21,6	-	-	28
32	-	25,4	26,3	26,2	26,9	26,3	24,5	23,7	21,5	20,3	17,7	-	32
36	-	-	21,9	22,3	22,7	22,1	21,1	20,7	19,1	18,0	16,7	12,9	36
40	-	-	18,8	19,0	18,8	18,6	18,8	17,8	17,3	16,4	15,3	12,7	40
48	-	-	-	14,2	14,5	14,2	14,2	13,8	13,4	12,5	11,4	10,9	48
56	-	-	-	10,9	11,2	10,9	10,9	10,5	10,3	9,7	9,1	7,9	56
64	-	-	-	-	8,8	8,8	8,6	8,2	7,9	7,9	6,8	5,7	64
72	-	-	-	-	-	6,9	6,7	6,4	6,0	6,0	5,1	4,2	72
80	-	-	-	-	-	-	5,3	4,9	4,6	4,6	4,0	2,9	80
88	-	-	-	-	-	-	4,3	3,8	3,5	3,5	2,9	1,9	88
96	-	-	-	-	-	-	-	2,9	2,5	2,7	2,0	-	96
104	-	-	-	-	-	-	-	-	2,3	1,8	1,9	-	104
1)	31,3	19,6	13,4	9,7	7,3	5,1	3,5	2,0	0	0	0	0	1)

26,700 lb		22.6 x 14.8 ft		360°		265 kW*		85 %					
ft	34.1 ft	45.6 ft	57.1 ft	68.6 ft	80.1 ft	91.5 ft	103.0 ft	114.5 ft	126.0 ft	137.5 ft	149.0 ft	164.0 ft	ft
1,000 lb													
10	86,5	86,6	86,5	84,6	-	-	-	-	-	-	-	-	10
12	78,6	79,6	79,0	78,4	71,6	-	-	-	-	-	-	-	12
14	70,2	71,2	71,2	70,9	65,1	60,6	-	-	-	-	-	-	14
16	63,1	64,2	64,4	61,4	58,0	52,7	-	-	-	-	-	-	16
18	54,1	55,5	55,8	53,7	51,0	46,4	39,4	-	-	-	-	-	18
20	45,0	47,4	48,3	48,3	44,7	40,8	37,5	33,8	-	-	-	-	20
24	-	35,0	35,8	35,6	35,2	34,5	32,4	28,9	26,6	-	-	-	24
28	-	27,3	27,8	27,8	28,7	28,0	26,9	25,7	23,3	21,6	-	-	28
32	-	21,9	22,7	23,4	23,2	22,7	22,6	22,2	20,8	19,4	17,7	-	32
36	-	-	19,5	19,8	19,6	19,4	19,5	18,8	18,4	17,6	16,2	12,9	36
40	-	-	16,4	16,6	16,9	16,6	16,6	16,4	16,0	15,5	14,5	12,7	40
48	-	-	-	12,6	12,8	12,7	12,6	12,4	12,0	11,6	11,1	10,8	48
56	-	-	-	9,9	10,1	10,0	9,9	9,6	9,3	9,4	9,0	8,4	56
64	-	-	-	-	8,1	8,0	7,9	7,7	7,4	7,4	7,0	6,6	64
72	-	-	-	-	-	6,4	6,4	6,2	6,0	6,0	5,5	5,1	72
80	-	-	-	-	-	-	5,3	4,9	4,7	4,7	4,5	3,8	80
88	-	-	-	-	-	-	4,4	4,1	3,9	3,9	3,5	3,0	88
96	-	-	-	-	-	-	-	3,3	3,1	3,1	2,7	2,2	96
104	-	-	-	-	-	-	-	2,7	2,5	2,5	2,1	-	104
1)	28,9	17,2	12,1	8,8	6,6	5,1	3,7	2,6	1,5	0	0	0	1)

* see page 23

1) Capacities with horizontal boom

		10,400 lb		22.6 x 14.8 ft		360°		265 kW*		85 %					
															
		34.1 ft	45.6 ft	57.1 ft	68.6 ft	80.1 ft	91.5 ft	103.0 ft	114.5 ft	126.0 ft	137.5 ft	149.0 ft	164.0 ft		
ft		1,000 lb											ft		
10		86,0	86,3	85,4	75,4	-	-	-	-	-	-	-	-	10	
12		76,0	75,3	68,4	62,7	55,3	-	-	-	-	-	-	-	12	
14		62,5	61,3	57,3	51,7	46,1	42,8	-	-	-	-	-	-	14	
16		46,6	49,4	47,8	43,6	40,7	37,5	-	-	-	-	-	-	16	
18		37,4	40,2	40,2	37,8	36,3	32,9	30,6	-	-	-	-	-	18	
20		29,9	32,3	33,2	34,1	31,7	29,1	27,8	26,1	-	-	-	-	20	
24		-	23,5	24,8	25,2	25,0	24,3	22,9	21,2	19,8	-	-	-	24	
28		-	17,8	19,2	19,4	19,7	19,6	19,0	17,7	16,3	15,7	-	-	28	
32		-	14,1	15,3	15,5	15,9	15,7	15,5	14,9	13,9	13,2	12,1	-	32	
36		-	-	12,7	12,9	13,3	13,1	12,9	12,6	11,9	11,4	10,3	9,1	36	
40		-	-	10,5	10,8	11,0	10,8	10,8	10,5	10,1	9,7	8,6	7,5	40	
48		-	-	-	7,8	8,0	8,0	7,8	7,6	7,4	7,4	6,3	5,4	48	
56		-	-	-	5,9	6,1	6,0	5,9	5,7	5,5	5,5	4,6	3,5	56	
64		-	-	-	-	4,7	4,6	4,5	4,2	4,0	4,0	3,1	2,2	64	
72		-	-	-	-	-	3,6	3,3	3,1	2,9	2,9	2,0	-	72	
80		-	-	-	-	-	-	2,6	2,3	-	-	-	-	80	
88		-	-	-	-	-	-	1,9	-	-	-	-	-	88	
1)		18,5	10,8	7,5	5,3	3,7	2,4	1,5	0	0	0	0	0	1)	

		7,100 lb		22.6 x 14.8 ft		360°		265 kW*		85 %					
															
		34.1 ft	45.6 ft	57.1 ft	68.6 ft	80.1 ft	91.5 ft	103.0 ft	114.5 ft	126.0 ft	137.5 ft	149.0 ft	164.0 ft		
ft		1,000 lb											ft		
10		85,6	85,9	80,7	70,0	-	-	-	-	-	-	-	-	10	
12		73,8	70,7	64,7	57,2	50,3	-	-	-	-	-	-	-	12	
14		57,2	55,8	52,2	46,9	42,7	39,5	-	-	-	-	-	-	14	
16		42,2	45,1	43,5	39,5	37,6	34,1	-	-	-	-	-	-	16	
18		33,8	36,6	36,5	34,8	32,8	30,0	28,4	-	-	-	-	-	18	
20		26,9	29,3	30,8	30,8	28,6	27,3	25,4	23,5	-	-	-	-	20	
24		-	21,2	22,5	22,9	23,2	22,0	20,6	19,1	17,6	-	-	-	24	
28		-	16,1	17,3	17,5	18,0	17,7	17,0	15,8	14,5	13,9	-	-	28	
32		-	12,6	13,7	14,0	14,3	14,1	14,0	13,3	12,1	11,7	10,5	-	32	
36		-	-	11,3	11,7	12,0	11,7	11,6	11,2	10,4	10,0	9,0	7,7	36	
40		-	-	9,3	9,7	9,9	9,7	9,5	9,3	8,8	8,4	7,5	6,4	40	
48		-	-	-	6,9	7,2	7,0	6,9	6,7	6,3	6,1	5,2	4,1	48	
56		-	-	-	5,1	5,4	5,2	5,1	4,9	4,6	4,4	3,6	2,5	56	
64		-	-	-	-	4,0	4,0	3,8	3,6	3,3	3,1	2,3	-	64	
72		-	-	-	-	-	2,9	2,9	2,7	2,2	2,0	-	-	72	
80		-	-	-	-	-	-	2,1	-	-	-	-	-	80	
1)		16,5	9,5	6,6	4,4	3,1	2,0	0	0	0	0	0	0	1)	

* see page 23

1) Capacities with horizontal boom



		16,300 lb		22.6 x 9.8 ft		360°		265 kW*		85 %				
		34.1ft	45.6ft	57.1ft	68.6ft	80.1ft	91.5ft	103.0ft	114.5ft	126.0ft	137.5ft	149.0ft	164.0ft	
ft		1,000 lb											ft	
10		68,1	64,0	58,4	51,9	-	-	-	-	-	-	-	-	10
12		51,5	51,2	47,6	44,0	40,7	-	-	-	-	-	-	-	12
14		38,7	41,3	39,9	38,0	34,8	32,6	-	-	-	-	-	-	14
16		30,5	32,8	34,2	32,7	30,9	28,5	-	-	-	-	-	-	16
18		25,4	27,4	28,9	28,4	27,4	25,4	23,9	-	-	-	-	-	18
20		20,9	22,9	24,2	24,4	24,2	22,6	21,3	19,6	-	-	-	-	20
24		-	17,0	18,2	18,5	18,9	18,4	17,5	16,2	15,0	-	-	-	24
28		-	13,3	14,2	14,7	14,9	14,7	14,5	13,5	12,4	11,8	-	-	28
32		-	10,6	11,5	11,8	12,0	12,0	11,8	11,2	10,3	10,0	8,9	-	32
36		-	-	9,6	9,8	10,1	10,1	9,8	9,5	8,8	8,5	7,5	6,4	36
40		-	-	8,0	8,2	8,4	8,4	8,2	8,0	7,5	7,1	6,2	5,1	40
48		-	-	-	6,0	6,2	6,1	5,9	5,7	5,5	5,2	4,2	3,1	48
56		-	-	-	4,5	4,7	4,5	4,4	4,2	3,8	3,6	2,7	-	56
64		-	-	-	-	3,5	3,3	3,3	3,1	2,6	2,4	-	-	64
72		-	-	-	-	-	2,4	2,4	2,0	1,8	-	-	-	72
1)		13,4	8,2	5,5	3,7	2,6	1,5	0	0	0	0	0	0	1)

		10,400 lb		22.6 x 9.8 ft		360°		265 kW*		85 %				
		34.1ft	45.6ft	57.1ft	68.6ft	80.1ft	91.5ft	103.0ft	114.5ft	126.0ft	137.5ft	149.0ft	164.0ft	
ft		1,000 lb											ft	
10		57,5	54,2	49,3	45,6	-	-	-	-	-	-	-	-	10
12		43,2	43,2	41,0	37,8	34,9	-	-	-	-	-	-	-	12
14		32,2	34,7	34,3	31,9	29,9	27,3	-	-	-	-	-	-	14
16		25,2	27,5	28,9	27,5	25,9	23,8	-	-	-	-	-	-	16
18		20,8	22,9	24,3	23,9	22,9	21,1	19,7	-	-	-	-	-	18
20		17,0	19,0	20,3	20,5	20,1	18,7	17,4	16,1	-	-	-	-	20
24		-	14,0	15,1	15,5	15,8	15,1	14,1	13,0	11,9	-	-	-	24
28		-	10,7	11,7	12,1	12,4	12,2	11,6	10,7	9,8	9,3	-	-	28
32		-	8,4	9,4	9,7	9,9	9,7	9,6	8,9	8,0	7,6	6,7	-	32
36		-	-	7,8	8,0	8,2	8,1	8,0	7,5	6,8	6,4	5,4	-	36
40		-	-	6,2	6,5	6,7	6,7	6,5	6,2	5,6	5,3	4,3	-	40
48		-	-	-	4,7	4,9	4,7	4,7	4,3	3,8	3,4	2,5	-	48
56		-	-	-	3,3	3,5	3,3	3,3	2,9	2,4	2,1	-	-	56
64		-	-	-	-	2,6	2,4	2,2	1,9	-	-	-	-	64
1)		10,6	6,2	4,2	2,6	1,8	0	0	0	0	0	0	0	1)

		7,100 lb		22.6 x 9.8 ft		360°		265 kW*		85 %				
		34.1ft	45.6ft	57.1ft	68.6ft	80.1ft	91.5ft	103.0ft	114.5ft	126.0ft	137.5ft	149.0ft	164.0ft	
ft		1,000 lb											ft	
10		51,4	49,0	45,4	41,1	-	-	-	-	-	-	-	-	10
12		38,6	38,9	36,8	34,0	31,3	-	-	-	-	-	-	-	12
14		28,7	31,1	30,7	28,6	26,7	24,5	-	-	-	-	-	-	14
16		22,3	24,6	25,8	24,6	23,1	21,3	-	-	-	-	-	-	16
18		18,3	20,4	21,8	21,3	20,5	18,8	17,5	-	-	-	-	-	18
20		14,8	16,8	18,1	18,4	18,0	16,5	15,4	14,1	-	-	-	-	20
24		-	12,3	13,4	13,8	14,1	13,4	12,4	11,3	10,2	-	-	-	24
28		-	9,3	10,4	10,6	10,9	10,7	10,1	9,2	8,3	7,9	-	-	28
32		-	7,2	8,2	8,5	8,8	8,5	8,3	7,6	6,7	6,4	5,5	-	32
36		-	-	6,6	7,0	7,2	7,1	6,9	6,3	5,5	5,2	4,3	-	36
40		-	-	5,4	5,6	5,8	5,8	5,6	5,1	4,5	4,1	3,2	-	40
48		-	-	-	3,8	4,1	3,8	3,8	3,4	2,7	2,5	-	-	48
56		-	-	-	2,6	2,8	2,6	2,6	2,2	-	-	-	-	56
64		-	-	-	-	1,9	-	-	-	-	-	-	-	64
1)		9,0	5,3	3,5	2,2	0	0	0	0	0	0	0	0	1)

* see page 23 1) Capacities with horizontal boom

Telescoping capacities

		360°											265 kW*	85 %
														
		45.6ft	57.1ft	68.6ft	80.1ft	91.5ft	103.0ft	114.5ft	126.0ft	137.5ft	149.0ft	164.0ft		
ft		1,000 lb											ft	
10		31,5	26,0	25,3	-	-	-	-	-	-	-	-	-	10
12		31,2	25,7	24,6	23,0	-	-	-	-	-	-	-	-	12
14		31,1	25,2	23,2	22,5	22,0	-	-	-	-	-	-	-	14
16		30,8	25,0	22,6	22,1	20,7	-	-	-	-	-	-	-	16
18		29,6	24,7	22,2	21,6	19,7	19,4	-	-	-	-	-	-	18
20		28,3	24,4	21,8	21,1	19,3	18,9	18,6	-	-	-	-	-	20
24		26,7	24,0	21,2	20,5	18,5	18,1	17,2	13,1	-	-	-	-	24
28		26,7	23,7	20,7	19,8	17,8	17,4	15,4	12,6	12,2	-	-	-	28
32		26,7	23,6	20,3	19,1	17,1	16,7	13,8	12,0	11,7	11,6	-	-	32
36		-	22,4	20,0	18,6	16,7	16,1	12,6	11,6	11,3	11,0	-	-	36
40		-	22,0	19,6	18,2	16,3	15,3	11,5	11,2	10,7	10,5	-	-	40
48		-	-	18,5	16,8	15,7	12,2	10,7	10,4	9,9	9,1	-	-	48
56		-	-	15,1	14,7	14,4	11,7	10,1	9,7	9,2	7,8	-	-	56
64		-	-	-	12,8	12,4	11,1	9,6	9,1	8,5	6,6	-	-	64
72		-	-	-	-	10,2	10,4	9,3	8,6	7,5	5,7	-	-	72
80		-	-	-	-	-	8,8	8,1	8,1	6,5	5,0	-	-	80
88		-	-	-	-	-	7,4	6,7	6,7	5,9	4,4	-	-	88
96		-	-	-	-	-	-	5,6	5,6	5,2	3,9	-	-	96
104		-	-	-	-	-	-	4,5	4,5	4,3	3,4	-	-	104
112		-	-	-	-	-	-	-	-	3,5	2,9	-	-	112
120		-	-	-	-	-	-	-	-	3,0	2,6	-	-	120
128		-	-	-	-	-	-	-	-	-	2,3	-	-	128
136		-	-	-	-	-	-	-	-	-	1,9	-	-	136
1)		22,9	17,6	13,4	10,8	7,9	6,4	4,4	3,3	2,2	1,5	-	-	1)

* see page 23

1) Capacities with horizontal boom

26,700 lb 22.6 x 21.3 ft 360° 265 kW* 85 %

164.0 ft

ft	27.9 ft			52.5 ft		
	0°	20°	40°	0°	20°	40°
	1,000 lb					
40	7,7	-	-	-	-	-
48	7,6	-	-	4,0	-	-
56	7,5	7,7	-	4,0	-	-
64	7,3	7,4	-	4,0	-	-
72	6,6	6,8	6,9	4,0	4,0	-
80	6,1	6,1	6,3	3,9	4,0	-
88	5,4	5,6	5,7	3,7	4,0	4,4
96	4,3	4,9	5,0	3,6	3,8	4,3
104	3,4	3,9	4,3	3,0	3,6	4,0
112	2,6	3,0	3,5	2,2	3,0	3,5
120	-	2,3	2,7	-	2,3	3,1
128	-	-	1,9	-	-	2,4
136	-	-	-	-	-	1,7

149.0 ft

ft	27.9 ft			52.5 ft		
	0°	20°	40°	0°	20°	40°
	1,000 lb					
40	10,8	-	-	6,2	-	-
48	10,4	-	-	6,2	-	-
56	9,9	9,8	-	6,2	-	-
64	9,2	9,0	9,0	6,2	-	-
72	8,4	8,2	8,2	6,0	5,7	-
80	7,3	7,4	7,6	5,7	5,5	4,9
88	6,0	6,6	6,8	5,3	5,2	4,9
96	4,8	5,4	5,7	4,5	4,9	4,7
104	3,7	4,3	4,5	3,4	4,5	4,4
112	3,3	3,3	3,5	2,6	3,5	4,4
120	2,5	2,7	3,0	2,3	2,9	3,6
128	2,0	2,2	2,3	1,8	2,2	2,8
136	-	-	-	-	1,8	1,9
144	-	-	-	-	-	1,6

137.5 ft

ft	27.9 ft			52.5 ft		
	0°	20°	40°	0°	20°	40°
	1,000 lb					
36	13,1	-	-	-	-	-
40	12,9	-	-	8,1	-	-
48	12,2	12,2	-	7,9	-	-
56	11,3	11,0	10,8	7,7	-	-
64	10,1	9,9	9,7	7,4	6,2	-
72	8,8	9,1	8,8	7,1	6,0	-
80	7,5	7,9	8,0	6,5	5,7	5,1
88	6,6	6,7	7,0	5,7	5,5	5,0
96	5,4	5,8	6,0	5,0	5,4	4,9
104	4,3	4,8	5,0	4,3	4,7	4,9
112	3,3	3,7	3,9	3,5	4,1	4,4
120	2,7	2,9	3,1	2,7	3,3	3,8
128	2,2	2,3	2,3	2,0	2,5	3,0
136	1,8	2,0	-	-	1,9	2,3
144	-	-	-	-	-	1,6

126.0 ft

ft	27.9 ft			52.5 ft		
	0°	20°	40°	0°	20°	40°
	1,000 lb					
32	17,1	-	-	-	-	-
36	16,4	-	-	9,3	-	-
40	15,7	-	-	9,2	-	-
48	14,1	13,7	-	8,7	-	-
56	12,4	12,2	12,0	8,5	6,8	-
64	10,7	10,9	10,8	8,0	6,4	-
72	9,1	9,5	9,7	7,5	6,2	5,3
80	7,9	7,9	8,5	6,9	5,9	5,2
88	6,9	7,0	7,0	6,2	5,6	5,1
96	5,7	6,1	6,2	5,3	5,4	4,9
104	4,8	5,1	5,2	4,7	4,9	4,9
112	3,9	4,3	4,4	3,9	4,4	4,4
120	3,2	3,4	-	3,2	3,6	4,0
128	2,5	2,8	-	2,5	3,1	3,3
136	2,0	2,1	-	2,0	2,4	2,8
144	-	-	-	-	1,8	2,0

114.5 ft

ft	27.9 ft			52.5 ft		
	0°	20°	40°	0°	20°	40°
	1,000 lb					
28	20,7	-	-	-	-	-
32	19,8	-	-	10,4	-	-
36	18,8	-	-	10,1	-	-
40	17,7	16,2	-	9,9	-	-
48	15,3	15,0	13,5	9,6	-	-
56	13,2	13,3	12,8	8,9	7,0	-
64	11,5	11,6	11,5	8,3	6,7	-
72	9,7	10,0	10,4	7,7	6,2	5,3
80	8,6	8,5	8,6	7,1	5,9	5,2
88	7,0	7,4	7,4	6,3	5,6	5,1
96	6,1	6,3	6,5	5,7	5,5	5,1
104	5,2	5,6	5,6	4,9	4,9	4,9
112	4,4	4,6	-	4,2	4,6	4,6
120	3,6	3,8	-	3,6	3,8	4,2
128	3,1	-	-	3,1	3,3	3,5
136	-	-	-	2,4	2,8	-
144	-	-	-	2,0	2,2	-

34.1 ft

ft	27.9 ft			52.5 ft		
	0°	20°	40°	0°	20°	40°
	1,000 lb					
10	29,5	-	-	17,2	-	-
12	28,9	-	-	16,6	-	-
14	28,1	-	-	16,1	-	-
16	27,1	21,1	-	15,5	-	-
18	26,0	20,3	-	14,9	-	-
20	24,9	19,5	-	14,2	-	-
24	22,6	18,2	15,4	12,9	-	-
28	20,3	16,9	14,8	11,5	9,2	-
32	18,2	16,0	14,2	10,7	8,7	-
36	16,5	15,2	13,9	9,9	8,2	-
40	14,8	14,5	13,7	9,1	7,6	-
48	12,5	-	-	7,7	6,7	6,0
56	-	-	-	6,8	6,2	5,6
64	-	-	-	6,1	5,6	5,3
72	-	-	-	5,3	5,3	-

* see page 23

10,400 lb 22.6 x 21.3 ft 360° 265 kW* 85 %

164.0 ft

ft	27.9 ft			52.5 ft		
	0°	20°	40°	0°	20°	40°
	1,000 lb					
40	7,7	-	-	-	-	-
48	7,6	-	-	4,0	-	-
56	7,0	7,7	-	4,0	-	-
64	5,5	6,6	-	4,0	-	-
72	3,8	4,9	5,6	3,1	4,0	-
80	2,7	3,5	4,2	-	3,6	-
88	-	2,4	2,9	-	2,5	3,7
96	-	-	2,0	-	-	2,7
104	-	-	-	-	-	1,9

149.0 ft

ft	27.9 ft			52.5 ft		
	0°	20°	40°	0°	20°	40°
	1,000 lb					
40	10,8	-	-	6,2	-	-
48	10,3	-	-	6,2	-	-
56	8,5	9,3	-	6,2	-	-
64	6,7	7,3	8,2	5,3	-	-
72	4,9	5,8	6,2	4,4	5,5	-
80	3,8	4,5	5,1	3,1	4,5	4,8
88	2,6	3,4	3,8	2,2	3,4	4,3
96	1,8	2,4	2,9	-	2,4	3,4
104	-	-	2,1	-	1,6	2,5

137.5 ft

ft	27.9 ft			52.5 ft		
	0°	20°	40°	0°	20°	40°
	1,000 lb					
36	13,1	-	-	-	-	-
40	12,9	-	-	8,1	-	-
48	11,5	12,1	-	7,9	-	-
56	9,4	10,0	10,4	7,4	-	-
64	7,0	8,2	8,6	6,3	6,2	-
72	5,8	6,2	6,9	4,9	5,7	-
80	4,6	5,1	5,3	4,0	4,9	5,0
88	3,5	4,0	4,5	3,0	3,9	4,6
96	2,7	3,1	3,4	2,2	3,1	3,8
104	1,9	2,3	2,5	-	2,3	3,2
112	-	-	-	-	-	2,4

126.0 ft

ft	27.9 ft			52.5 ft		
	0°	20°	40°	0°	20°	40°
	1,000 lb					
32	17,1	-	-	-	-	-
36	16,4	-	-	9,3	-	-
40	15,6	-	-	9,2	-	-
48	12,5	13,2	-	8,7	-	-
56	10,2	10,6	11,1	8,1	6,8	-
64	8,2	8,9	9,2	7,0	6,4	-
72	6,2	7,1	7,7	5,8	6,2	5,3
80	4,9	5,5	6,0	4,5	5,6	5,2
88	3,8	4,3	4,7	3,5	4,5	5,0
96	2,8	3,2	3,6	2,7	3,6	4,3
104	2,1	2,3	2,6	1,9	2,7	3,4
112	-	-	-	-	-	2,6

114.5 ft

ft	27.9 ft			52.5 ft		
	0°	20°	40°	0°	20°	40°
	1,000 lb					
28	20,7	-	-	-	-	-
32	19,8	-	-	10,4	-	-
36	18,1	-	-	10,1	-	-
40	16,3	16,1	-	9,9	-	-
48	13,0	13,6	13,4	9,6	-	-
56	10,8	11,0	11,5	8,7	7,0	-
64	8,8	9,1	9,5	7,7	6,7	-
72	6,9	7,5	8,0	6,6	6,2	5,3
80	5,3	6,0	6,4	5,3	5,8	5,2
88	4,3	4,7	4,9	4,3	5,1	5,1
96	3,2	3,6	3,9	3,3	4,1	4,6
104	2,3	2,7	3,0	2,5	3,2	3,7
112	-	-	-	-	2,4	2,8
120	-	-	-	-	-	2,1

34.1 ft

ft	27.9 ft			52.5 ft		
	0°	20°	40°	0°	20°	40°
	1,000 lb					
10	29,5	-	-	17,2	-	-
12	28,9	-	-	16,6	-	-
14	28,1	-	-	16,1	-	-
16	27,1	21,1	-	15,5	-	-
18	26,0	20,3	-	14,9	-	-
20	24,9	19,5	-	14,2	-	-
24	22,6	18,2	15,4	12,9	-	-
28	20,3	16,9	14,8	11,5	9,2	-
32	18,2	16,0	14,2	10,7	8,7	-
36	16,5	15,2	13,9	9,9	8,2	-
40	14,8	14,5	13,7	9,1	7,6	-
48	12,5	-	-	7,7	6,7	6,0
56	-	-	-	6,8	6,2	5,6
64	-	-	-	6,1	5,6	5,3
72	-	-	-	5,3	5,3	-

* see page 23

7,100 lb 22.6 x 21.3 ft 360° 265 kW* 85 %

164.0 ft

ft	27.9 ft			52.5 ft		
	0°	20°	40°	0°	20°	40°
	1,000 lb					
40	7,7	-	-	-	-	-
48	7,6	-	-	4,0	-	-
56	6,4	7,2	-	4,0	-	-
64	4,3	5,5	-	3,5	-	-
72	2,9	3,8	4,7	2,2	4,0	-
80	-	2,5	3,3	-	2,7	-
88	-	-	2,2	-	-	-

149.0 ft

ft	27.9 ft			52.5 ft		
	0°	20°	40°	0°	20°	40°
	1,000 lb					
40	10,8	-	-	6,2	-	-
48	9,8	-	-	6,2	-	-
56	7,5	8,5	-	5,8	-	-
64	5,7	6,5	7,1	4,8	-	-
72	4,0	4,9	5,5	3,3	4,9	-
80	2,7	3,6	4,2	2,3	3,6	4,6
88	-	2,5	2,9	-	2,6	3,7
96	-	-	2,0	-	-	2,7
104	-	-	-	-	-	1,9

137.5 ft

ft	27.9 ft			52.5 ft		
	0°	20°	40°	0°	20°	40°
	1,000 lb					
36	13,1	-	-	-	-	-
40	12,8	-	-	8,1	-	-
48	10,8	11,7	-	7,9	-	-
56	8,2	9,4	9,7	6,8	-	-
64	6,5	7,0	7,9	5,5	6,2	-
72	4,9	5,8	6,0	4,4	5,5	-
80	3,6	4,4	4,9	3,1	4,5	4,9
88	2,6	3,3	3,8	2,2	3,4	4,1
96	1,8	2,4	2,8	-	2,4	3,3
104	-	-	1,9	-	1,6	2,5

126.0 ft

ft	27.9 ft			52.5 ft		
	0°	20°	40°	0°	20°	40°
	1,000 lb					
32	17,1	-	-	-	-	-
36	15,7	-	-	9,3	-	-
40	14,5	12,9	-	9,2	-	-
48	11,7	12,3	10,7	8,6	-	-
56	9,3	9,9	10,5	7,6	6,8	-
64	7,0	7,9	8,5	6,4	6,4	-
72	5,3	6,2	6,9	4,9	6,0	5,3
80	4,0	4,7	5,3	3,6	4,9	5,1
88	3,0	3,6	4,0	2,6	3,8	4,7
96	2,1	2,5	2,9	1,8	2,8	3,6
104	-	1,6	1,9	-	2,1	2,7

114.5 ft

ft	27.9 ft			52.5 ft		
	0°	20°	40°	0°	20°	40°
	1,000 lb					
28	20,7	-	-	-	-	-
32	19,7	-	-	10,4	-	-
36	17,3	-	-	10,1	-	-
40	15,3	16,0	-	9,9	-	-
48	12,6	12,8	13,1	9,4	-	-
56	10,0	10,5	10,8	8,3	7,0	-
64	7,9	8,6	9,0	7,2	6,7	-
72	6,0	6,7	7,3	5,8	6,2	5,3
80	4,6	5,1	5,5	4,5	5,5	5,2
88	3,5	4,0	4,3	3,4	4,4	4,9
96	2,5	3,0	3,2	2,4	3,4	4,1
104	1,8	2,1	2,3	1,8	2,5	3,2
112	-	-	-	-	-	2,4

34.1 ft

ft	27.9 ft			52.5 ft		
	0°	20°	40°	0°	20°	40°
	1,000 lb					
10	29,5	-	-	17,2	-	-
12	28,9	-	-	16,6	-	-
14	28,1	-	-	16,1	-	-
16	27,1	21,1	-	15,5	-	-
18	26,0	20,3	-	14,9	-	-
20	24,9	19,5	-	14,2	-	-
24	22,6	18,2	15,4	12,9	-	-
28	20,3	16,9	14,8	11,5	9,2	-
32	18,2	16,0	14,2	10,7	8,7	-
36	16,5	15,2	13,9	9,9	8,2	-
40	14,8	14,5	13,7	9,1	7,6	-
48	12,5	-	-	7,7	6,7	6,0
56	-	-	-	6,8	6,2	5,6
64	-	-	-	6,1	5,6	5,3
72	-	-	-	5,3	5,3	-

* see page 23

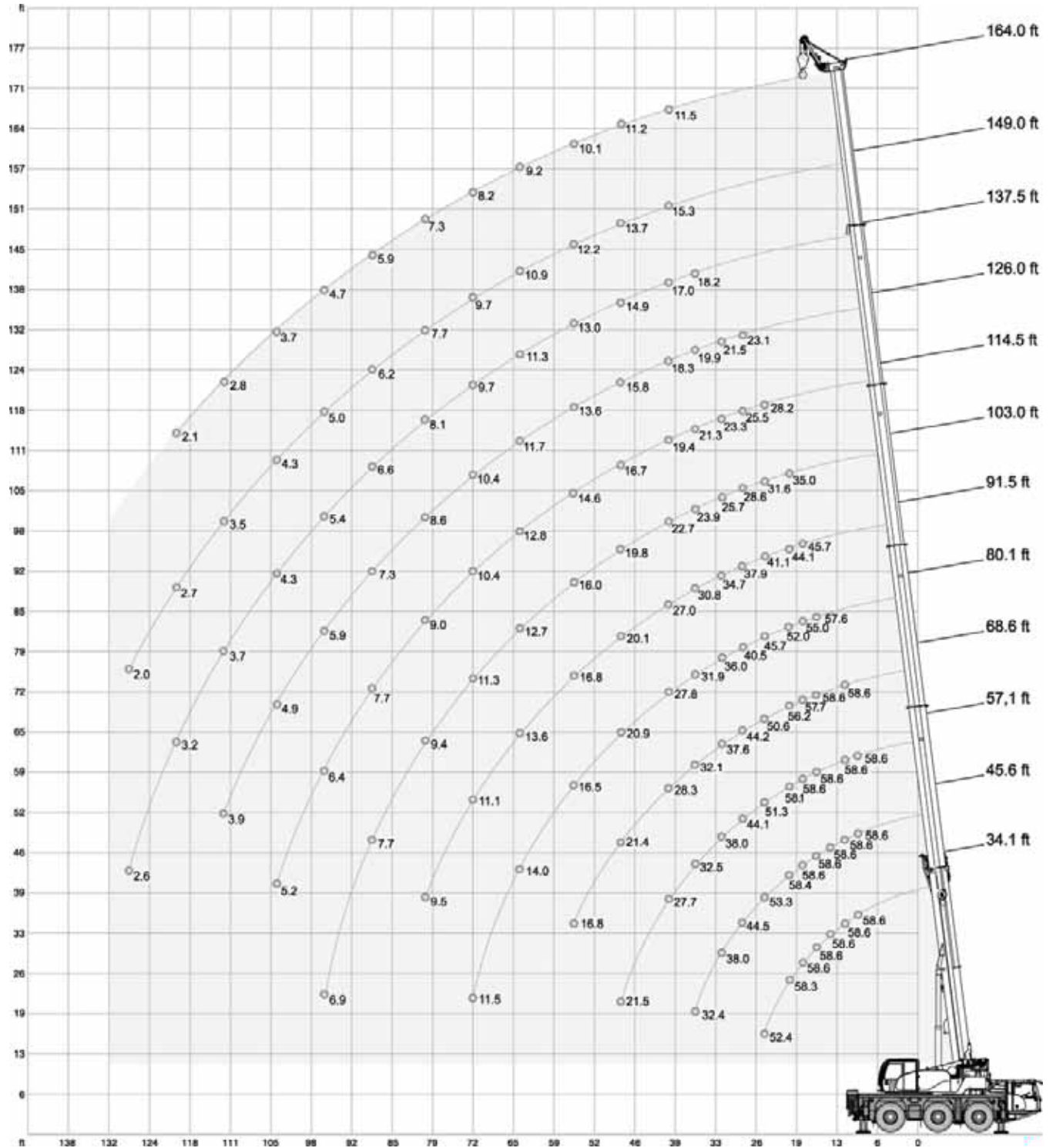
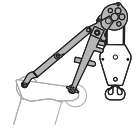

		26,700 lb		22.6 x 21.3 ft		360°		265 kW*		85 %																
		34.1 ft		45.6 ft		57.1 ft		68.6 ft		80.1 ft		91.5 ft		103.0 ft		114.5 ft		126.0 ft		137.5 ft		149.0 ft		164.0 ft		
		1,000 lb																								
		ft																								
10		58,6	58,6	58,6	-	-	-	-	-	-	-	-	-	-	-	-	-	-	-	-	-	-	-	-	-	10
12		58,6	58,6	58,6	58,6	-	-	-	-	-	-	-	-	-	-	-	-	-	-	-	-	-	-	-	-	12
14		58,6	58,6	58,6	58,6	-	-	-	-	-	-	-	-	-	-	-	-	-	-	-	-	-	-	-	-	14
16		58,6	58,6	58,6	58,6	57,6	-	-	-	-	-	-	-	-	-	-	-	-	-	-	-	-	-	-	-	16
18		58,6	58,6	58,6	57,7	55,0	45,7	-	-	-	-	-	-	-	-	-	-	-	-	-	-	-	-	-	-	18
20		58,3	58,4	58,1	56,2	52,0	44,1	35,0	-	-	-	-	-	-	-	-	-	-	-	-	-	-	-	-	-	20
24		52,4	53,3	51,3	50,6	45,7	41,1	31,6	28,2	-	-	-	-	-	-	-	-	-	-	-	-	-	-	-	-	24
28		43,7	44,5	44,1	44,2	40,5	37,9	28,6	25,5	23,1	-	-	-	-	-	-	-	-	-	-	-	-	-	-	-	28
32		-	38,0	38,0	37,6	36,0	34,7	25,7	23,3	21,5	-	-	-	-	-	-	-	-	-	-	-	-	-	-	-	32
36		-	32,4	32,5	32,1	31,9	30,8	23,9	21,3	19,9	18,2	-	-	-	-	-	-	-	-	-	-	-	-	-	-	36
40		-	-	27,7	28,3	27,8	27,0	22,7	19,4	18,3	17,0	15,3	11,5	-	-	-	-	-	-	-	-	-	-	-	-	40
48		-	-	21,5	21,4	20,9	20,1	19,8	16,7	15,8	14,9	13,7	11,2	-	-	-	-	-	-	-	-	-	-	-	-	48
56		-	-	-	16,8	16,5	16,8	16,0	14,6	13,6	13,0	12,2	10,1	-	-	-	-	-	-	-	-	-	-	-	-	56
64		-	-	-	-	14,0	13,6	12,7	12,8	11,7	11,3	10,9	9,2	-	-	-	-	-	-	-	-	-	-	-	-	64
72		-	-	-	-	11,5	11,1	11,3	10,4	10,4	9,7	9,7	8,2	-	-	-	-	-	-	-	-	-	-	-	-	72
80		-	-	-	-	-	9,5	9,4	9,0	8,6	8,1	7,7	7,3	-	-	-	-	-	-	-	-	-	-	-	-	80
88		-	-	-	-	-	-	7,7	7,7	7,3	6,6	6,2	5,9	-	-	-	-	-	-	-	-	-	-	-	-	88
96		-	-	-	-	-	-	6,9	6,4	5,9	5,4	5,0	4,7	-	-	-	-	-	-	-	-	-	-	-	-	96
104		-	-	-	-	-	-	-	5,2	4,9	4,3	4,3	3,7	-	-	-	-	-	-	-	-	-	-	-	-	104
112		-	-	-	-	-	-	-	-	3,9	3,7	3,5	2,8	-	-	-	-	-	-	-	-	-	-	-	-	112
120		-	-	-	-	-	-	-	-	-	3,2	2,7	2,1	-	-	-	-	-	-	-	-	-	-	-	-	120
128		-	-	-	-	-	-	-	-	-	2,6	2,0	-	-	-	-	-	-	-	-	-	-	-	-	-	128
1)		29,8	21,8	17,4	13,0	10,4	7,7	6,2	4,2	3,1	1,8	0	0	-	-	-	-	-	-	-	-	-	-	-	1)	

* see page 23

1) Capacities with horizontal boom

10,400 lb		22.6 x 21.3 ft		360°		265 kW*		85 %					
ft	34.1 ft	45.6 ft	57.1 ft	68.6 ft	80.1 ft	91.5 ft	103.0 ft	114.5 ft	126.0 ft	137.5 ft	149.0 ft	164.0 ft	ft
1,000 lb													
10	58,6	58,6	58,6	-	-	-	-	-	-	-	-	-	10
12	58,6	58,6	58,6	58,6	-	-	-	-	-	-	-	-	12
14	58,6	58,6	58,6	58,6	-	-	-	-	-	-	-	-	14
16	58,6	58,6	58,6	58,6	57,6	-	-	-	-	-	-	-	16
18	58,6	58,6	58,6	57,4	54,5	45,7	-	-	-	-	-	-	18
20	57,6	57,8	57,5	55,0	50,7	44,0	35,0	-	-	-	-	-	20
24	44,9	46,3	45,7	43,1	39,9	39,1	31,6	28,2	-	-	-	-	24
28	33,9	35,3	35,4	34,9	34,4	31,9	28,6	25,5	23,1	-	-	-	28
32	-	28,0	29,0	29,1	28,3	26,5	25,3	23,3	21,5	-	-	-	32
36	-	23,7	24,2	24,2	23,6	22,5	22,3	20,2	19,1	18,0	-	-	36
40	-	-	20,1	20,1	20,1	20,1	19,2	18,2	17,1	16,4	15,2	11,5	40
48	-	-	14,8	15,5	15,3	14,9	15,1	14,2	14,2	13,4	12,3	10,9	48
56	-	-	-	11,9	11,9	11,9	11,6	11,5	11,0	10,2	9,2	8,5	56
64	-	-	-	-	9,7	9,5	9,3	8,9	8,4	7,9	7,5	6,3	64
72	-	-	-	-	7,8	7,5	7,3	6,9	6,4	6,4	5,6	4,5	72
80	-	-	-	-	-	6,0	5,8	5,3	4,9	4,9	4,2	3,1	80
88	-	-	-	-	-	-	4,7	4,3	3,8	3,8	3,2	2,2	88
96	-	-	-	-	-	-	3,8	3,2	2,8	2,8	2,2	-	96
104	-	-	-	-	-	-	-	2,3	2,1	1,9	-	-	104
1)	28,2	17,9	12,1	9,3	6,8	4,9	3,3	2,0	0	0	0	0	1)

7,100 lb		22.6 x 21.3 ft		360°		265 kW*		85 %					
ft	34.1 ft	45.6 ft	57.1 ft	68.6 ft	80.1 ft	91.5 ft	103.0 ft	114.5 ft	126.0 ft	137.5 ft	149.0 ft	164.0 ft	ft
1,000 lb													
10	58,6	58,6	58,6	-	-	-	-	-	-	-	-	-	10
12	58,6	58,6	58,6	58,6	-	-	-	-	-	-	-	-	12
14	58,6	58,6	58,6	58,6	-	-	-	-	-	-	-	-	14
16	58,6	58,6	58,6	58,6	57,6	-	-	-	-	-	-	-	16
18	57,9	58,3	56,5	55,4	52,7	45,7	-	-	-	-	-	-	18
20	55,9	56,8	53,2	51,1	47,0	43,7	35,0	-	-	-	-	-	20
24	41,6	43,0	42,4	39,9	38,9	36,2	31,6	28,2	-	-	-	-	24
28	31,2	32,5	32,7	33,5	31,7	29,5	27,4	25,4	23,1	-	-	-	28
32	-	26,2	27,0	26,8	26,0	24,6	24,1	22,1	20,7	-	-	-	32
36	-	21,8	22,5	22,2	21,7	21,7	20,8	19,3	18,0	17,1	-	-	36
40	-	-	18,5	18,6	19,0	18,5	18,1	17,5	16,7	15,8	14,9	11,4	40
48	-	-	14,0	14,2	14,0	14,2	13,8	13,6	13,2	12,0	11,0	10,2	48
56	-	-	-	10,9	11,0	10,9	10,7	10,3	9,9	9,1	8,5	7,3	56
64	-	-	-	-	8,8	8,6	8,4	7,9	7,5	7,3	6,3	5,1	64
72	-	-	-	-	6,9	6,7	6,4	6,0	5,6	5,5	4,7	3,6	72
80	-	-	-	-	-	5,3	5,1	4,5	4,2	4,2	3,4	2,3	80
88	-	-	-	-	-	-	3,8	3,4	2,9	2,9	2,4	-	88
96	-	-	-	-	-	-	3,0	2,4	2,0	2,0	-	-	96
104	-	-	-	-	-	-	-	1,8	-	-	-	-	104
1)	26,0	16,3	11,0	8,4	6,2	4,2	2,6	0	0	0	0	0	1)

* see page 23

1) Capacities with horizontal boom

Ratings are in compliance with ASME B30.5.

Lifting capacities do not exceed 85 % of tipping load.

Weight of hook blocks and slings is part of the load, and is to be deducted from the capacity ratings.

Consult operation manual for further details.

Note: Data published herein is intended as a guide only and shall not be construed to warrant applicability for lifting purposes.

Crane operation is subject to the computer charts and operation manual both supplied with the crane.

Lifting capacities may vary slightly when equipped with the 240 kW engine due to the lower vehicle gross weight.

The telescopic loads stated in the capacity chart are valid under the following conditions:

- The sliding areas of the telescopes must be lubricated well.
- The surroundings temperature has to be normal (considerable reductions must be expected below 0 °C).
- The radius in the chart is given for the end length of the telescopic sequence.
- The capacities are valid for extending and retracting the telescopic section.
- The telescopic loads are only valid for moving the last section of the sequence. The curve for e. g. 0-0-45-90-90 % is only valid for telescoping from 0-0-0-90-90 % to 0-0-45-90-90 % and back, but not for 0-0-0-0-0 % to 0-0-45-90-90 %!
- The telescopic loads are based on the telescoping ability of the boom. The loads to be telescoped must never exceed the loads in the load chart as tipping of the crane may occur.
- The most advantageous individual telescoping sequence is shown. Other telescoping sequences for the same boom length will result in lower lifting capacities for telescoping. Refer to the machine's documentation for these lifting capacity values.

Basic equipment

Carrier P54100 / P12100

Engine 240-3b	MTU (Mercedes); output 240 kW (326 HP), torque 1300 Nm, certifications in accordance with EURO MOT 3b, TIER 4i, CARB; MTU (Mercedes) exhaust system made of stainless steel with SCR catalyst.
Fuel tank 320-40	85 gallons Diesel; 10.5 gallons Ad-Blue.
Transmission AS-MID	ZF AS-Tronic Mid; automated gearbox with 12 forward speeds and 2 reverse; 2-stage transfer case with switchable off-road gear and switchable longitudinal lock.
Axles 6 x 4 x 6	6 x 4 x 6; 3 axles, axles 1 and 3 permanently driven and equipped with shiftable transverse lock; all axles steered.
Suspension	Hydropneumatic suspension with axle load compensation; hydraulically lockable; manual or automatic levelling alternatively, $\pm 4.3''$.
Steering	Dual circuit hydro servocom steering with emergency steering pump; active rear axle steering.
Brakes	Pneumatic dual circuit service brake with antilock system, acting on all wheels; disc brakes; additional exhaust brake and constant throttle valve; spring-loaded parking brake.
Wheels 38595 170F	385/95R25 (14.00R25); steel rims 9,5-25/1,7ET90; 170F.
Cab carrier 2550	Type 8.4 ft; adjustable driver seat with seat heating, armrests and pneumatic suspension; steering wheel height and tilt adjustable; power door windows; tinted glass; aircondition- and radio preparation; 2 integrated rotary beacons; storage area.
Drive lights	With low beam, upper beam, daytime running lights.
Cruise control	Automatic speed control including automatic brake control.
Dry sideways compartment	Dry sideways compartment on co-driver's side.
StorageBox	Top opening storage box in the carrier tail; not possible in combination HookBox.
ChainBox	Special storage box for 4-stranded lifting chain, behind carrier cab.
Electronic immobiliser system	Prevents uncontrolled carrier mobilisation; incl. 2 electronic keys.
Pneumatic tire filling plug	Pneumatic tire filling plug for self-filling of the wheels.

Crane

Telescopic boom HA50	31.4 - 164.0 ft; single cylinder telescoping system, automatic telescoping; attachments for all equipment and extensions; 3 sheaves integrated in boom head for max. capacity of 87,100 lb.
Counterweight 5	10,400 lb; automatic rigging system; expandable to max. 26,700 lb; 26,700 lb can be carried on board serially.
Outriggers	H-4-Point design; vertical and horizontal movement fully hydraulic; manual or automatic levelling alternatively on both sides of carrier; 3 outrigger bases.
Outrigger pads 020	4 round outrigger pads A = 0.66 ft ² with transport position at vertical cylinder.
Boom luffing	Single luffing cylinder with automatic lowering brake valve.
Rotary drive	Single slewing gear unit with spring-loaded multi-disc brake.
H1	Hoist with spring-loaded multi-disc brake; resolver (hoist rotation indicator).
Drive	Hydraulic system with power control; hydraulic oil cooler.
Control system	Enabling 4 simultaneous working movements; electric pilot controls via 2 two-axis joysticks.
Operator aids	IC-1, with integrated load moment indicator acc. EN13000; colour display; displaying of current operating conditions, load charts, fault indicator; signal lights indicating LMI-load; crane data logger.
Cab crane 0875	Type 2.9 ft; tilt variable 20°; seat heating; fold-out front window; extendable side and foldable front pedestal; handrails; tinted safety glass; pull-down sun visor and light curtains; aircondition- and radio preparation.

Diverse

VarioHeat 12	Engine-dependent warm water heating with 12 kW heating power; switchable between carrier cab and crane cab.
Illumination	1 x adjustable for work prefield at crane cab, 4 x for outriggers.
Rotary beacons 2	2 x integrated on carrier cab, 2 x disconnectable on crane tail.
Jump starting device NATO 1	Jump starting device according to NATO-standard; enabling jump start by using separate energy source.
Contour safety marking	Continuous, white reflecting bands at carrier sides and tail.

Power train variant

Engine 265-3b	MTU (Mercedes); output 265 kW (360 HP), torque 1750 Nm, certifications in accordance with EURO MOT 3b, TIER 4i, CARB; MTU (Mercedes) exhaust system made of stainless steel with SCR catalyst.
Transmission AS12INT	ZF AS-Tronic; automated gearbox with integrated hydraulic retarder, 12 forward speeds and 2 reverse; 2-stage transfer case with switchable off-road gear and switchable longitudinal lock; not possible in combination with eddy-current brake.

Optionen (free configurable)

Carrier

Axles 6 x 6 x 6	6 x 6 x 6; all 3 axles steered, axles 1 and 3 permanently driven, axle 2 shiftable, all axles equipped with shiftable transverse lock.
Wearless auxiliary brake	Telma; wearless auxiliary eddy-current brake at 3rd axle. Only together with engine 240-3b.
Wheels 44595 174F	445/95R25 (16.00R25); steel rims 11-25/1,7ET90; 174F.
Wheels 52580 179E	525/80R25 (20.50R25); steel rims 17-25/1,7ET50; incl. carrier broadening to 9 ft.
Long range fuel tank 150	40 gallons; for total 125 gallons Diesel and 10.5 gallons Ad-Blue; not possible in combination with hook block storage.

Crane

Remote control RK H2	Full control of rigging and crane movements via wireless remote control. 2. hoist; spring-loaded multi-disc brake; resolver (hoist rotation indicator); incl. quick couplings and transport storage; enables 2-hook operation with all extensions.
Additional counterweight 7	16,300 lb; for max. 26,700 lb.
Outrigger load indicator	Displayed in LMI crane cab.
Outrigger basis monitoring	Surveillance of each outrigger beam for visual comparison with the programmed outrigger basis; displayed in LMI crane cab (Attention, there is no automatic linkage with the LMI-system).
Moving out of crane cab	Control of carrier out of crane cab, enables machine moving when rigged, possible even under load.

Extensions

HAV16	27.9 ft / 52.5 ft; double folding swing-away jib, with spindle bolting, manual offset 20° / 40°; 1-sheave head; incl. transport storage; includes HAV9.
MSF2	4.8 ft; fixed assembly jib; 2-sheave for max. capacity 58,700 lb; incl. transport storage at carrier tail (not possible together with KombiBoxes at tail).
R1	Swing-away rooster sheave, incl. transport storage; for single-reeving operation with elevated hook height.

Diverse

VarioCool 7	Aircondition with 7 kW cooling power; switchable between carrier cab and crane cab.
VarioHeat Plus 10	Auxiliary, engine independent Diesel heating system with 10 kW heating power; remote control with programmable timer; switchable between engine block, carrier cab and crane cab.
VarioHook 50-3B-18-D	50-3B-18-D (662-1,210 lb); hook block with adjustable ballast and ramshorn hook, variable usage as 1- and 3-sheave hook block; white with red signal stripes.
VarioHook 50-3B-18-E	50-3B-18-E (662-1,210 lb); hook block with adjustable ballast and single hook, variable usage as 1- and 3-sheave hook block; white with red signal stripes
Hook block 50-3-18-D	50-3-18-D (1,210 lb); hook block with ramshorn hook; white with red signal stripes.
Hook block 50-3-18-E	50-3-18-E (1,210 lb); hook block with single hook; white with red signal stripes.
Hook block 20-1-18-E	20-1-18-E (662 lb); hook block with single hook; white with red signal stripes.
Hook 8-0V-E	8-0V-E (374 lb); single hook with vertical swivel; red.

Weight data may deviate from posted values based on road / travel configuration, equipment configuration, and component weight tolerances.

Effective Date: October 2012.

Product specifications and prices are subject to change without notice or obligation. The photographs and/or drawings in this document are for illustrative purposes only. Refer to the appropriate Operator's Manual for instructions on the proper use of this equipment. Failure to follow the appropriate Operator's Manual when using our equipment or to otherwise act irresponsibly may result in serious injury or death. The only warranty applicable to our equipment is the standard written warranty applicable to the particular product and sale and Terex makes no other warranty, express or implied. Products and services listed may be trademarks, service marks or trade-names of Terex Corporation and/or its subsidiaries in the USA and other countries. All rights are reserved. Terex® is a registered trademark of Terex Corporation in the USA and many other countries.

Copyright 2012 Terex Corporation

Terex Cranes, Global Marketing, Dinglerstraße 24, 66482 Zweibrücken, Germany
Tel. +49 (0) 6332 830, Email: info.cranes@terex.com, www.terexcranes.com



www.terexcranes.com

Brochure Reference: TC-DS-I-E-Challenger 3180 - 10/12



TEREX®

WORKS FOR YOU.™